

Notice for All Users

- Consult the operation manual (this document) for proper use of your computer.
- The product and the accessories are subject to change without prior notice.
- SHARP assumes no responsibility for results arising from use of pre-installed and third party software. Consult the software vendor for resolution of problems. (Read the service condition of the software before use.)
- SHARP assumes no responsibility for problems caused by incorrect handling, repairs, defects, battery replacement or any other cause.

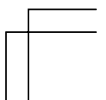
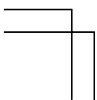
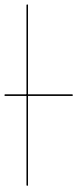
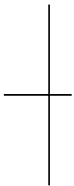

Notice for Users in the USA

FCC Statement

WARNING - FCC Regulations state that any unauthorized changes or modifications to these equipments not expressly approved by the manufacturer could void the user's authority to operate these equipments.

Note: These equipments have been tested and found to comply with the limits for a Class B digital device pursuant to Part 15 of the FCC Rules.

These limits are designed to provide reasonable protection against harmful interference in a residential installation. These equipments generate, use and can radiate radio frequency energy and, if not installed and used in accordance with the instructions, may cause harmful interference to radio communications. However, there is no guarantee that interference will not occur in a particular installation. If these equipments do cause harmful interference to radio or television reception, which can be determined by turning the equipments off and on, the user is encouraged to try to correct the interference by one or more of the following measures:

- Reorient or relocate the receiving antenna.
- Increase the distance between the equipment and receiver.
- Connect the equipment into an outlet on a circuit different from that to which the receiver is connected.
- Consult the dealer or an experienced radio/TV technician for help.

A shielded I/F cable is required to insure compliance with FCC regulation for Class B computing equipment.

* As an ENERGY STAR[®] Partner, SHARP has determined that this product meets the ENERGY STAR[®] guidelines for energy efficiency.

Declaration of Conformity

SHARP PERSONAL COMPUTER, PC-MC Series

This device complies with part 15 of the FCC rules. Operation is subject to the following conditions:(1) this device may not cause harmful interference, and (2) this device must accept any interference received, including interference that may cause undesired operation.

Responsible Party: SHARP ELECTRONICS CORPORATION
Sharp Plaza, Mahwah, New Jersey 07430-2135
TEL: 1-800-BE-SHARP

This device complies with the FCC RF exposure requirements.



About the Modem

This equipment complies with Part 68 of FCC rules. On the bottom of this equipment is a label that contains, among other information, the FCC registration number and ringer equivalence number (REN) for this equipment. If requested, this information must be provided to the telephone company.

The modem jack of this equipment complies with Sub-part F of Part 68 of FCC rules.

The REN is used to determine the quantity of devices which may be connected to the telephone line. Excessive RENs on the telephone line may result in the devices not ringing in response to an incoming call. In most, but not all areas, the sum of the RENs should not exceed five (5.0). To be certain of the number of devices that may be connected to the line, as determined by the total RENs contact the telephone company to determine the maximum REN for the calling areas.

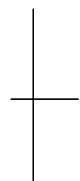
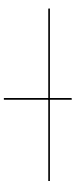



If the terminal equipment causes harm to the telephone network, the telephone company will notify you in advance that temporary discontinuance of service may be required. But if advance notice isn't practical, the telephone company will notify the customer as soon as possible. Also, you will be advised of your right to file a complaint with the FCC if you believe it necessary.

The telephone company may make changes in its facilities, equipment, operations, or procedures that could affect the operation of the equipment. If this happens, the telephone company will provide advance notice in order for you to make the necessary modifications in order to maintain uninterrupted service.

If trouble is experienced with this equipment, please contact Sharp Electronics Corp. for repair and (or) warranty information (Refer to the end of this section). If the trouble is causing harm to the telephone network, the telephone company may request you remove the equipment from the network until the problem is resolved.

The equipment cannot be used on public coin service provided by the telephone company. Connection to Party Line Service is subject to state tariffs. (Contact the state public utility commission, public service commission or corporation commission for information.)



The Telephone Consumer Protection Act of 1991 makes it unlawful for any person to use a computer or other electronic device, including fax machines, to send any message unless such message clearly contains in a margin at the top or bottom of each transmitted page or on the first page of the transmission, the date and time it is sent and an identification of the business or other entity, or other individual sending the message and the telephone number of the sending machine or such business, other entity, or individual. (The telephone number provided may not be a 900 number or any other number for which charges exceed local or long-distance transmission charges.) To program this information, refer to the manual of the communication software.

Warning

This product utilizes tin-lead solder, and fluorescent lamp containing a small amount of mercury.
Disposal of these materials may be regulated due to environmental considerations. For disposal or recycling information, please contact your local authorities or the Electronics Industries Alliance: www.eiae.org

Copyright

It is the intent of Sharp that this product be used in full compliance with the copyright laws of the United States and that prior permission be obtained from copyright owners whenever necessary.

Product Information and Customer Assistance

For Product Information and Customer Assistance:

Call: 1-800-BE-SHARP (237-4277)

Sharp Systems of America

5901 Bolsa Avenue, Huntington Beach, CA 92647

Home Page: <http://www.sharpsystems.com>

E-mail address: ssa-support@sharpsystems.com



Notice for Users in Canada

This class B digital apparatus complies with Canadian ICES-003.

About the Wireless LAN



Operation is subject to the following conditions: (1) this device may not cause harmful interference, and (2) this device must accept any interference received, including interference that may cause undesired operation.

This product contains IC: 4023-MIWLGR1

About the Modem

This product meets the applicable Industry Canada technical specifications. The Ringer Equivalence Number is an indication of the maximum number of devices allowed to be connected to a telephone interface. The termination on an interface may consist of any combination of devices subject only to the requirement that the sum of the RENs of all the devices does not exceed five (REN:0.2).

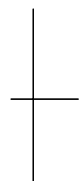
This product contains IC: 4023-11777

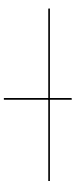



CAUTION:

TO PREVENT ELECTRICAL SHOCK, DISCONNECT THE AC CORD AND REMOVE THE BATTERY BEFORE SERVICING.

CAUTION:

FOR A COMPLETE ELECTRICAL DISCONNECTION, PULL OUT THE MAINS PLUG AND THE BATTERY.

VORSICHT:

UM DIE STROMZUFUHR VOLLSTÄNDIG ZU UNTERBRECHEN, DEN NETZSTECKER HERAUSZIEHEN UND DIE BATTERIE ENTFERNEN.

ATTENTION:

POUR UN ARRET TOTAL DU SYSTEME, DECONNECTEZ LA PRISE DE COURANT SECTEUR ET LA BATTERIE.



WARNING:

FÖR TOTAL ELEKTRISK URKOPPLING, KOPPLA UR KONTAKTEN OCH TA UR BATTERIET.



PRECAUCION:

PARA UNA COMPLETA DESCONEXION ELECTRICA DESENCHUFE LA CLAVIJA DE LA RED Y LA BATERIA.





Safety Precautions

General

- Follow all cautions and instructions marked on your computer.
- Except as described elsewhere in this manual, refer all servicing to qualified personnel. Immediately shut off your computer and seek servicing under the following conditions:
 - when the power cord or plug is damaged or frayed
 - when liquid is spilled on your computer
 - when your computer has been dropped or the cabinet has been damaged

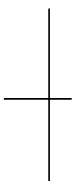
Location

- 
- 
- Do not expose your computer to direct sunlight.
 - Try to avoid dusty environments.
 - Keep your computer away from any magnetic devices and TVs.
 - Keep your computer away from excessive humidity or fluids such as rain, snow, water spray, juice, coffee, steam, etc.
 - Do not move your computer from an extremely cold place to an extremely warm place. A temperature difference of more than 18°F (10°C) will cause condensation inside the unit, which may cause damage. (In this case, turn off your computer and leave it for about an hour to completely dry the unit.)
 - Do not block or cover slots or openings on the cabinet. They protect your computer from overheating.
 - Do not place your computer on an unstable or uneven work surface.
 - Care should be exercised when using on heat sensitive surfaces or your lap as the base of your computer will become hot.
 - Do not use your computer on your lap or any part of your body for an extended period during operation or while charging to avoid injury from heat exposure.

Usage

- Never push any objects into cabinet openings. They may touch the dangerous voltage points or short parts that could result in fire or electrical shock.
- Do not press or place heavy objects on your computer. Strong pressure can damage the cabinet or make your computer fail.

- If your computer and AC power cord experience abnormal situation such as heat generation or smoking, or produces an abnormal odor, turn off your computer, unplug the power cord, and remove the battery pack immediately.
- Turn off your computer before installing or removing any peripheral devices except USB devices, a PC card, etc.
- Never subject your computer to sudden shocks or extreme vibration.
- Do not drop your computer nor hit it with other equipment.
- Do not scratch the surface of the LCD screen.
- Before cleaning, turn off your computer and disconnect the AC power cord.

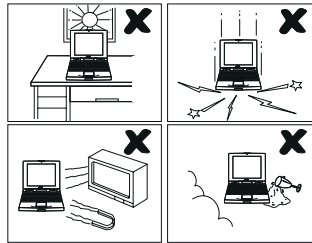

- When carrying your computer:
 - Turn off your computer.
 - Remove external media such as a PC card from the slot.
 - Disconnect the external peripherals, cables and cords if connected.
 - Do not subject your computer to shocks.
 - Do not hold your computer by the display unit.

Otherwise, your computer may be damaged or the stored data might be lost.

Battery Precautions

CAUTION

DANGER OF EXPLOSION IF BATTERY IS INCORRECTLY REPLACED. REPLACE ONLY WITH THE SAME OR EQUIVALENT TYPE RECOMMENDED BY THE MANUFACTURER. DISCARD USED BATTERIES ACCORDING TO THE INSTRUCTIONS.

Handling

- Do not put the battery pack in a fire, as it could explode and cause injury.

- Do not attempt to open or alter the battery pack.
- Do not place the battery pack where it might become hotter than 140°F (60°C).
- The battery pack must be kept from metal objects such as keys. They might trigger a short circuit and consequently cause the battery pack to heat up and explode.
- Do not allow liquids to come in contact with the battery pack.
- Care must be taken not to drop the pack. A violent shock damages the pack.
- Do not solder anything to the battery terminals.

Charging

- Charge the battery pack only with the AC adapter and AC power cord included with your computer.

Discharging



- Use the battery pack only for powering your computer. Do not use it for any other purpose.

Storage

- Store the battery pack in a cool and dry place. Do not store it in a place having temperatures of above 140°F (60°C).
- Recharge the stored battery pack before using it.

AC Power Precautions

- Plug the AC power cord directly in the wall jack. Plugging too many leads into a single socket may result in fire.
- Never plug in or remove the AC power cord or AC adapter with wet hands for prevention of electric shock.
- The included AC power cord must be appropriate for the voltage used in your area. Using an inappropriate cord can cause fire.
- Unplug the AC power cord when your computer is not used for a long period.
- Never disassemble, repair, or modify the AC adapter.
- Never modify, twist, forcibly bend or pull, or place heavy objects on top of the AC cord to avoid damaging it. Using a damaged cord can cause fire or electric shock.

- 
- 
- 
- Be sure to hold the plug of the AC power cord when you remove it from a wall socket.
 - Check the AC power cord and power connectors periodically for damage. If damage is found, change the power cord immediately.

Modem Precautions

IMPORTANT SAFETY INSTRUCTIONS

When using your telephone equipment, basic safety precautions should be always followed to reduce the risk of fire, electric shock and injury to persons, including the following:

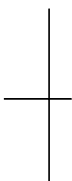
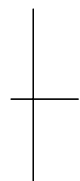
- 
- 
- Do not use this product near water (for example near a bath tub, wash bowl, kitchen sink or laundry tub), in a wet basement or near a swimming pool.
 - Avoid using any telephones (other than a cordless type) during an electrical storm. There may be a remote risk of electric shock from lightning.
 - Do not use the telephones to report a gas leak in the vicinity of the leak.
 - Never install a telephone wire during lightning storms.
 - During thunder storms, you should turn off your computer, unplug the AC power cord and remove the modem cable from your computer.
 - Never use telephone jacks in wet locations unless they are specifically designed for wet locations.
 - Never touch uninsulated telephone wires or terminals while they are connected to a network interface.
 - Use caution when you install or modify telephone lines.
 - Save these instructions.

Wireless LAN Precautions

- Disable the integrated antenna and do not communicate with wireless LAN in specific environments where radio-susceptible equipment is nearby, on airplanes, in hospitals, for example.
- Disable the integrated antenna and do not communicate with wireless LAN in crowded places for prevention of cardiac pacemaker interference.
- Maintain a space of at least 8.7" (22cm) between a cardiac pacemaker and the active wireless LAN antenna.

- Maintain a space of at least 7.9" (20cm) between the antenna and your body while communicating.
- Never disassemble or alter the wireless LAN unit.
- Do not remove the certification label on the wireless LAN unit.

Product Conformance

The wireless LAN unit equipped with your computer is in conformance with federal requirements. No license is required for use of the device.

Notice of Radio Interference

The wireless LAN unit equipped with your computer operates at 2.4GHz that is also used for microwaves, science or medical devices, other similar radio stations (hereafter called "other radio stations"), etc.

- Prior to using the wireless LAN function with your computer, confirm that no "other radio stations" are operating nearby.
- If interference with "other radio stations" is experienced, change the current channel set to your computer or move your computer. If it fails, stop operating your computer.



PC Disposal or Transfer

Before you dispose or transfer your computer, you should erase the data from hard disks.

To remove the data from the hard disk of your computer, you will need to:

- "Delete" the data by placing it in the Recycle Bin.
- Empty the Recycle Bin.
- Format the hard disk drives.
- Recover the system.

The above procedures do not completely delete all data from the hard disk drives. When a file is deleted, the disk location where it was stored is marked as unallocated space available for new data. It means that the old data is still there and can be recovered. It allows for malicious persons to recover the "deleted" data and misuse it. To avoid the data spillage, you must thoroughly erase all the data from the hard disks.



The following measures are recommended for permanent data deletion:

- Use special software or paid services for thoroughly erasing data.
- Hammer, or strongly magnetize, the hard disk to destroy the stored data.

Before you transfer your computer, delete any software in your computer including the operating system or applications to avoid conflict with the software agreement(s).

Other Precautions

- Periodic back-up copies of your important data should be made to protect your data in the event of hard disk failure or loss of the data. Use other storage devices for the backup.

For Your Health

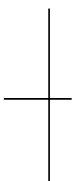
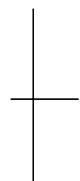
- 
- 
- Take regular breaks of ten to fifteen minutes after every hour of continuously viewing the screen to relieve your eyes.
 - Adjust the brightness for comfortable viewing. (Brightness level of about 500 lux is recommended.)
 - Avoid using your computer in an environment where sunlight or indoor lighting reflects off the screen.
 - Position the display slightly below eye level and give a space of 15.8" (40cm) through 23.7" (60cm) between you and the display.



Notice of Computer Security

The Windows operating system on this computer provides the Security Center, which manages the security features of the computer. It provides the status of the following security functions and enables you to change the settings.

- Firewall
- Automatic Updates
- Virus Protection

Be sure to confirm that the three functions are “ON” to ensure the safety of the computer.

To open the *Security Center*, click *start – Control Panel – Security Center*.

Firewall

The firewall function blocks unauthorized connection to this computer through the Internet or a network.



Automatic Updates



The automatic updates function periodically detects new security programs to be installed and automatically installs them.

Virus Protection

The Norton AntiVirus software, which automatically checks the virus infection, is preinstalled in this computer. To protect the computer against new viruses and other security threats, the virus definition file of the software must be updated. The virus protection function monitors whether the definition file is latest. On your computer with the preinstalled Norton AntiVirus software, however, the software monitors the definition file and notifies you when the file needs to be updated.

When the Windows setup is finished, be sure to complete the Norton AntiVirus wizard and LiveUpdate to update the definition file. (You must establish the connection to the Internet for the update.)

After completing the Norton AntiVirus wizard and LiveUpdate;

* The *Virus Protection* in the *Windows Security Center* always displays as *ON* regardless of the definition file status. Since the preinstalled Norton Antivirus software manages virus check on your computer, be sure to perform the LiveUpdate.

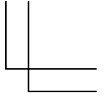
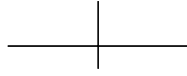
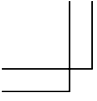

- * You can enable the LiveUpdate automatically to run and update the file if any updates are detected. (Refer to the *Virus Protection* section in the *Appendixes*.)
- * You will have the message “Your computer might be at risk” at the bottom right of the screen when one of the Firewall and Automatic updates is set to *OFF*.

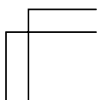
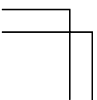
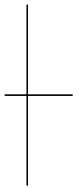
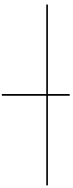



Notice of Security with Wireless Devices

Wireless LAN provides data transfer by means of electric waves instead of LAN cables between communicating devices such as personal computers and a wireless LAN station. Wireless LAN has an advantage of simple and ubiquitous LAN connection in the ranges where electric waves are available. Since electric waves can penetrate through walls and reach everywhere, wireless LAN without proper security settings includes some security threats and can produce the situations mentioned below.

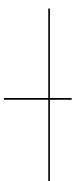
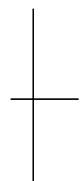
- Eavesdropping
Malicious third parties can intercept the transmission and monitor your mail to steal personal information such as an identification number, password, and credit card number.
 - Intruding
Malicious third parties can connect to a personal or office network without authorization and illegally perform the following:
 - Obtaining access to confidential customer records or sensitive corporate information (Information leakage)
 - Faking the original information (Spoofing)
 - Altering the monitored original data and transmitting (Falsification)
 - Spreading computer viruses resulting in the destruction of data or systems (Destruction)
- 
- 

Although wireless LAN cards and wireless LAN stations (Access Points) have security measures against the threats above, no security settings may have been configured at the time of your purchase.

All security features must be configured according to reference manuals of the wireless LAN devices, which results in reducing vulnerability to the attacks described above.

Use the wireless devices with a clear understanding that wireless LAN includes vulnerabilities that could allow attackers to simply bypass security features.

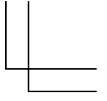
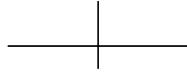
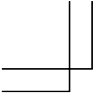

Security measures are important for all users to understand for a safe use of wireless LAN. SHARP encourages all users to configure the security settings with their own judgment and responsibility.

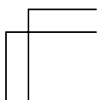
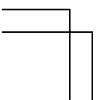
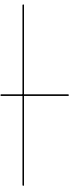
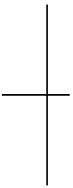



About This Manual

Notice

Information in this manual is subject to change without notice and does not represent a commitment on the part of SHARP Electronics Corporation and its sales subsidiaries.

SHARP Electronics Corporation and its sales subsidiaries shall not be liable for technical or editorial errors or omissions contained herein; nor for incidental or consequential damages resulting from the furnishing, performance, or use of this material.

SHARP strongly recommends that separate permanent written records be kept of all important data. Data may be lost or altered in virtually any electronic memory product under certain circumstances. Therefore, SHARP assumes no responsibility for data lost or otherwise rendered unusable whether as a result of improper use, repairs, defects, battery replacement, use after the specified battery life has expired, or any other causes.

SHARP assumes no responsibility directly or indirectly, for financial losses or claims from third persons resulting from the use of this product and any of its functions, such as stolen credit card numbers, the loss of or alteration of stored data, etc.

Copyright

© 2005 SHARP Electronics Corporation

This document contains or refers to proprietary information which is protected by copyright. All rights are reserved. Copying or other reproduction of this document is prohibited without the prior written permission of SHARP Electronics Corporation.

Trademarks

AMD, the AMD logo, AMD Athlon, and AMD PowerNow! are trademarks of Advanced Micro Devices, Inc.

IBM is a trademark of International Business Machines Corporation.

Microsoft and Windows are registered trademarks of Microsoft Corporation in the United States and other countries. Windows Media is a trademark of Microsoft Corporation in the United States and other countries.

WinDVD is a registered trademark of InterVideo, Inc.

Dolby and the double-D symbol are registered trademarks of Dolby Laboratories Licensing Corporation.

Power Quest is a registered trademark and EasyRestore is a trademark of PowerQuest Corporation.

BAPCo is a registered trademark of the Business Applications Performance Corporation.

MobileMark is a trademark of the Business Applications Performance Corporation.

All other brand and product names are trademarks or registered trademarks of their respective holders.



Recording Important Information

For future reference, please record the following information in the spaces provided below.

Model Number:

Serial Number:

Date of purchase:

Dealer's Name:

Place of purchase:

Password:

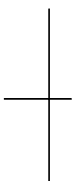

The serial number is printed on a sticker located on the bottom of your computer.

Manual Conventions

This manual uses a set of style conventions described below.

Notes and Cautions are italicized with icons:



A note icon informs you of a special technique or information that may help you perform a task or better understand a process.



A caution icon alerts you to something that may cause problems or damage to hardware, software or data.

Key Labels on the Keyboard, when referred to in the instructions, are shown in boldface:

Press **Enter** to continue.

When two or more keys are separated by a plus (+) sign, press and hold down the first key (or first two keys), and then press the last key:

Run *Task Manager* by pressing **Ctrl+Alt+Delete**.

Sample Entries are shown in lower cases of different typeface.

`c:\windows\system`

Words/Texts on Screen, such as window titles or possible parameters, are italicized:

Double-click this icon to display the *Power Options Properties* dialog box.

Set the item to *Enabled*.

Screens reproduced in this manual may differ slightly from the screens you see on your computer.

Section Titles in other parts of this manual are italicized:

Refer to *Installing Battery Pack* section of Chapter 1.

Table of Contents

Notice for All Users	i
Notice for Users in the U.S.A.	ii
Notice for Users in Canada	v
Safety Precautions	vii
Notice of Computer Security	xiii
Notice of Security with Wireless Devices	xv
About This Manual	xvii
Recording Important Information	xviii
Manual Conventions	xix
Table of Contents	xx
Overview of Computer	xxii

Basic Operations

Connecting to AC Power Source	1-1
Turning Off Your Computer	1-3
Choosing Power Source	1-4
Resetting System	1-6
Using Touchpad	1-7
Using Keyboard	1-9
Using Optical Drive	1-10
Controlling Volume	1-16
Adjusting Display	1-17
Sharing Your Computer	1-19

Battery and Power Management

Battery Pack	2-1
Power Management	2-7

Peripherals

Peripheral Device Ports	3-1
Optional External Floppy Disk Drive Unit	3-3
External Display	3-6
Audio System	3-8
USB Device	3-10
PC Card	3-11
Printer	3-14

Communication Functions

Built-in Modem	4-1
LAN Unit.....	4-4
Wireless LAN.....	4-9
Network Setup Utility.....	4-20

Setup Utility

Running Setup Utility.....	5-1
Main Menu	5-3
Advanced Menu.....	5-4
Security Menu	5-4
Exit Menu	5-6

Appendixes

Memory Module	A-1
Maintenance and Care	A-4
Virus Protection.....	A-10
Data Backup and Restore	A-13
Re-installation Instructions.....	A-14
Specifications	A-25

Troubleshooting

Common Problems	T-1
Trouble with Starting.....	T-2
Trouble with Display	T-3
Trouble with Keyboard/Touchpad.....	T-4
Trouble with Floppy Disks	T-5
Trouble with Hard Disks	T-6
Trouble with Optical Drive.....	T-6
Trouble with Communication.....	T-7
Trouble with Peripherals	T-11
Trouble with Security Settings	T-12
Other Troubles.....	T-12

Index	index-1
--------------------	---------

Overview of Computer

Each number after an arrow indicates the page referring to the part. Actual appearance of your computer may be slightly different depending on the model.

Front

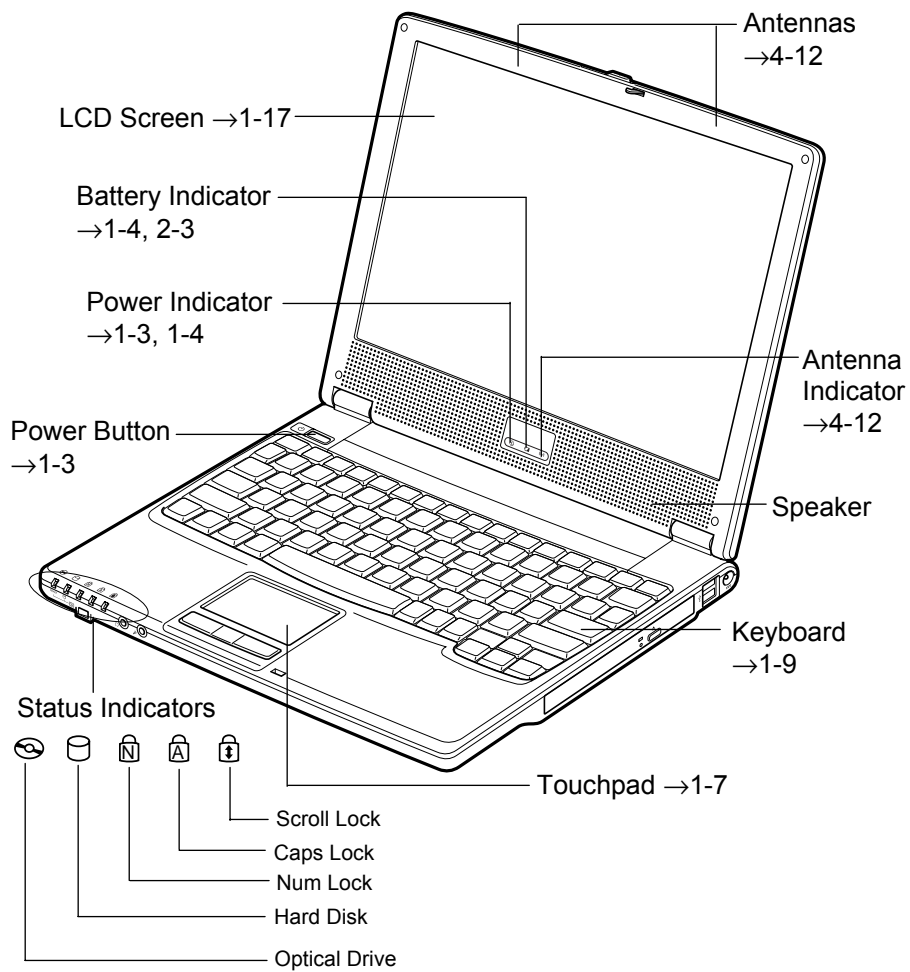

Never turn off the computer when the hard disk indicator or the optical drive indicator is on. This may damage the data on the hard disk.

Front

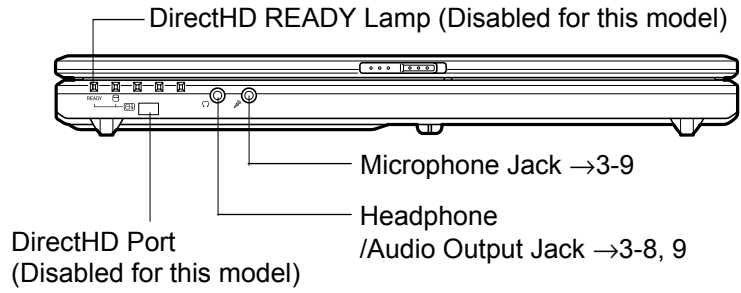

Right

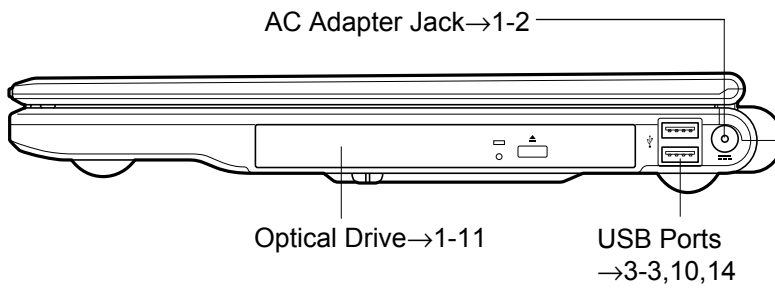

Left

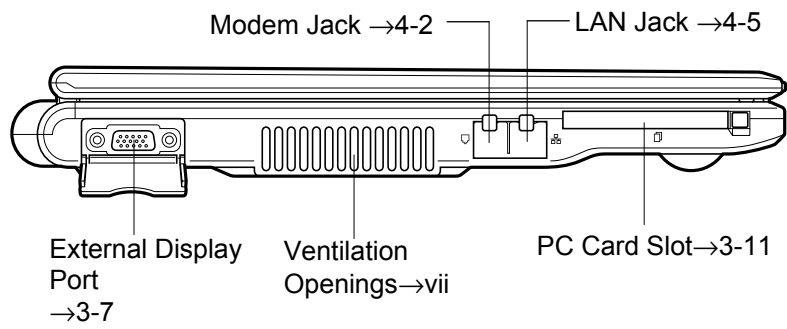

Rear

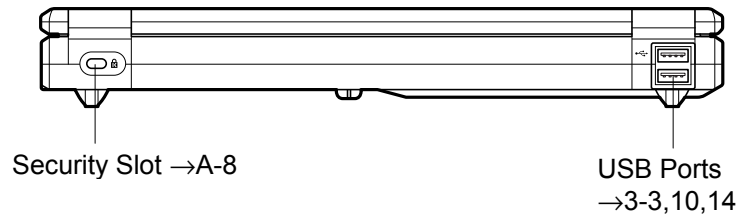

Bottom

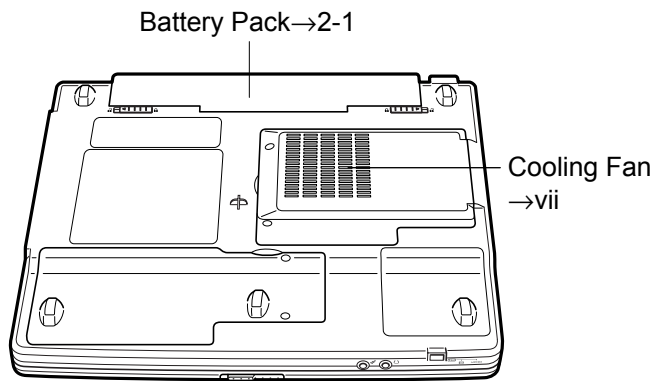

CHAPTER 1

Basic Operations

1

This chapter describes the basic operations of the computer.



Properties Dialog Box in Windows

In this manual, you will often see the expression “XXX Properties dialog box.” A dialog box is a window containing text boxes, check boxes, buttons, etc., with which you can send commands to Windows or other application programs. To open the properties dialog boxes, click start - Control Panel. The Control Panel has two types of views: Category view and Classic view. The Category view allows you to choose the category that may be related to what you want to do, then, choose the task by clicking it. The Classic view gives you the icons representing their components or features. Double-click one of the icons to open their dialog box or windows. Some of the dialog boxes you will use often are:

- *Display*
- *Phone and Modem Options*
- *Mouse*
- *Power Options*
- *System*

Clicking Switch to XXX View string appearing at the upper left of the Control Panel window allows you to toggle between the two views.

Connecting to AC Power Source



- *Always use the AC adapter and the AC power cord included with the computer. Using others may damage the computer.*
 - *Always hold the AC power cord by the plug when removing it from the wall outlet. Never pull on the cord.*
 - *Never plug in and out the AC power cord with your wet hands.*
-

1. Plug the AC adapter cable into the AC adapter jack on the right side of the computer.
2. Plug the AC power cord into the AC adapter.
3. Plug the AC power cord into a wall outlet.

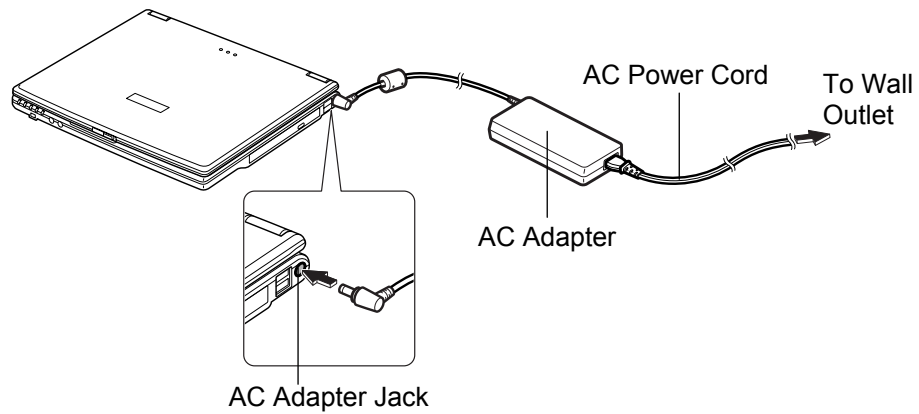
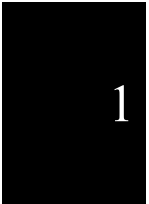

4. Slide the display cover lock lever to the right until the display cover releases, and raise the cover.

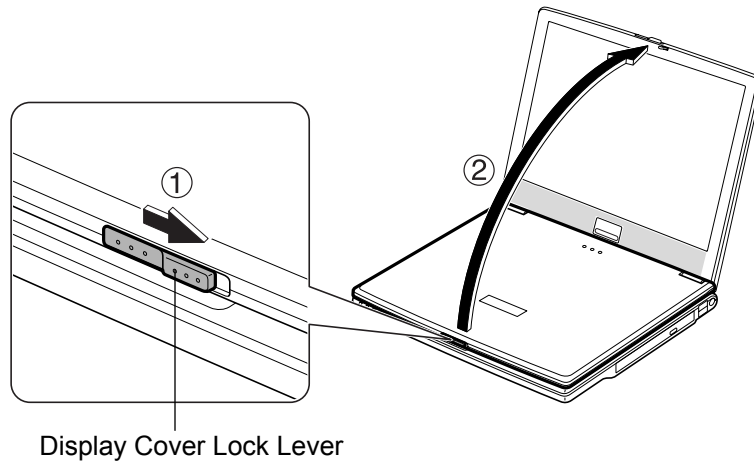

5. Press the power button to turn on the computer.

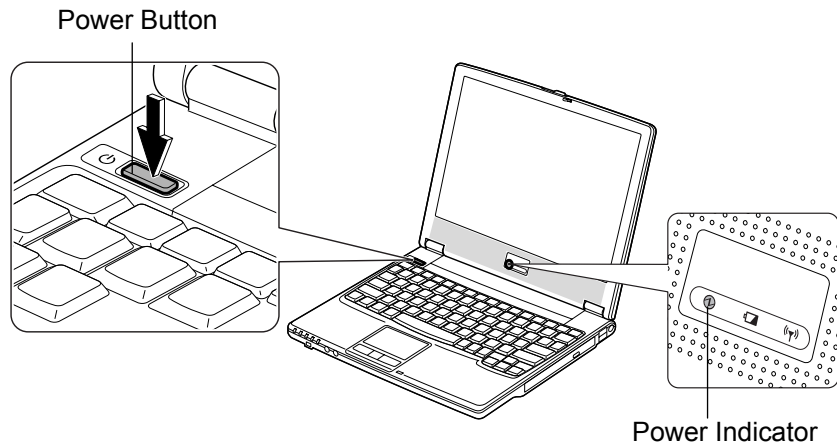

When you turn on the computer, the power indicator (1) turns green, the computer goes through a self test to detect any problems, and Windows setup process starts.



Do not touch or operate the keyboard and touchpad until Windows completely activates unless you are prompted to do. Otherwise, Windows may not start properly.

Turning Off Your Computer

When you've finished using the computer, turn it off with one of the following ways:

- From the *start* menu
 1. Click *start – Turn Off Computer*.
 2. In the *Turn off computer* dialog box, click *Turn Off*.
- With the power button

Before using this step, confirm that *Shut down* is selected in *When I press the power button on my computer* in *Advanced* tab of *Power Options Properties* dialog box.

Close the cover to keep the screen and keyboard clean and protected.



If you have not saved a file, a dialog box will appear asking whether you want to save it.



- Do not turn off or reset the computer while the hard disk indicator, the optical drive indicator, or the indicator on the optional external floppy disk drive unit is lit. Doing so may damage or even wipe out the data.
- Before turning it back on, wait at least ten seconds after turning off the computer. Turning the power off and on in rapid succession can damage the computer's electrical circuitry.

1

Choosing Power Source

You can use the computer with one of the following power sources:

- AC power from a wall outlet
Use AC power whenever possible; rely on the battery only when AC power is not available.
- Rechargeable battery
The computer is equipped with a standard battery pack. See Chapter 2 for the battery information.

About Power Indicators

The following indicators show the power status of the computer.

Indicator	Light	Meaning	
Power 	On (green)	Operating	
	Blinking (green)	In System Standby	
	Off	Powered off or in System Hibernate	
Battery 	Connected to AC Power Source	On (green)	Fully charged
		On (orange)	Being charged
		Blinking (orange)	In abnormal state (Remove the battery pack and install it again.)
	Powered by Battery	Off	Has power
Blinking (red)		Almost completely discharged (The warning beep sounds.)	

The battery indicator is always off when the computer is turned off and not connected to AC power source.



- When the battery is hot, the battery indicator may turn off and stay off until the battery becomes cool.
- For more information on System standby/hibernate, see Chapter 2.

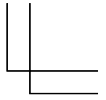
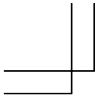

Using AC Adapter

When connected to a wall outlet, the AC adapter provides power for operation and charges the battery. The AC input voltage can range from 100 to 240 volts so that you can use the computer with the appropriate plug adapter.



The AC power cord included with the computer is appropriate for the voltage used in the area in which you purchased the computer. If you attempt to connect the computer to a wall outlet other than in this area, check the voltage of the outlet and use an AC power cord appropriate for the outlet. Consult local service staff if you are not sure.

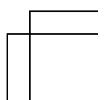
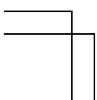
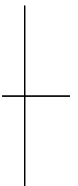
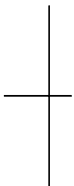

Resetting System

You may need to restart the system if the computer hangs up or new hardware or software is installed. When a message appears after the installation, click *OK*, *Yes*, etc. to restart Windows.

You can also restart Windows by clicking *start - Turn Off Computer*; then, *Restart*.



Resetting may cause data loss. Use the resetting process only if the normal Windows Shut Down does not work because of software malfunction. Although resetting will not damage the system, you may lose the data you are processing.

Warm Boot (Software Reset)

If the system is locked up because of a software problem, you can reset or reboot the system by pressing the **Ctrl+Alt+Del** keys simultaneously and select the *Applications* tab of the *Windows Task Manager* dialog box. Click the program name that hangs up, then, *End Task*. If this does not solve the problem, select the *User* tab click *Disconnect* or *Logoff* of the *Windows Task Manager* dialog box, then *Yes*.

Power Switch

You can turn off the computer with the power button if you encounter hardware or software problems that lock up the system. In this case, press the power button for more than four seconds.

Removing AC Adapter and Battery Pack

If pressing the power button fails to turn off the computer, follow these steps.

1. Confirm the hard disk indicator is off.
2. Remove the AC adapter, then, the battery pack.



Before removing the AC adapter and the battery pack, confirm the hard disk indicator is off.

3. Ten seconds later, reinstall the battery pack and then, connect the AC adapter.
4. Turn on the computer.

Using Touchpad

The computer is equipped with an integrated touchpad pointing device. Using the touchpad, you can move the pointer, select an item from a menu, and perform other tasks in the same way you would with a mouse.

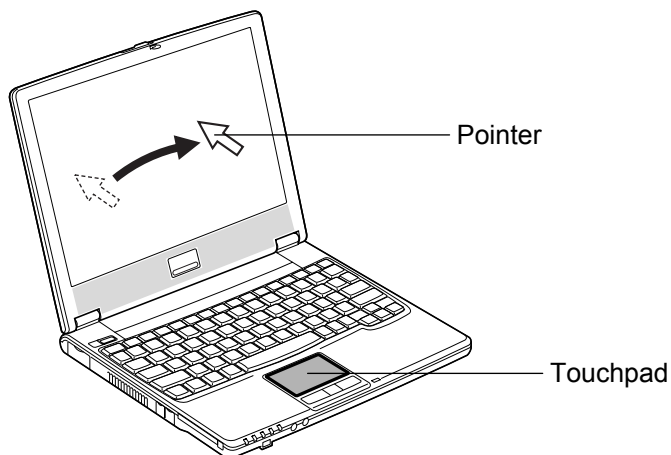

1



- *Do not hit or scratch the surface of the touchpad with pointed objects (such as a ballpoint pen).*
- *Do not operate the touchpad with a moist finger. This may cause the touchpad to operate incorrectly.*

Enabling Touchpad

When a USB mouse is connected to one of the USB ports of the computer, the touchpad is disabled, which means that the computer does not respond to any tapping on the pad. Therefore, conflict with the mouse and/or unexpected move of the pointer on the screen can be avoided.

To enable the touchpad, use one of the following ways.

- Disconnect the connected USB mouse. (No mouse must be connected.)
- With a USB mouse connected,
 1. Click *start - Control Panel*.
 2. Click *Printers and Other Hardware - Mouse*.
 3. In the *Mouse Properties* dialog box, click the *Device Settings* tab.

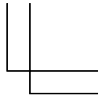
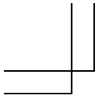

4. Clear the box of *Disable internal pointing device when external USB pointing device is attached*.
5. Click *OK* to close the dialog box.
6. Close the *Printers and Other Hardware* dialog box.

Completing the steps allows the computer always to respond to the touchpad, while the connected USB mouse also works.

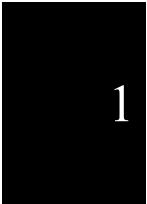

When the touchpad is disabled, the touchpad icon (🖱️) on the taskbar is crossed (🖱️).

Using Touchpad

Take a moment to become familiar with how the touchpad works.

Place Your Fingertip

Place your left or right hand next to the touchpad, resting your wrist naturally in a relaxed manner. Place your thumb or finger on the touchpad.

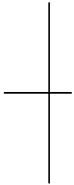

Move Your Fingertip

The rectangular pad of the touchpad is used to move the pointer around the display. As you slide your fingertip across the pad, the pointer on the screen moves in the same direction across the screen. The touchpad is very sensitive, so you do not have to exert much pressure on the pad. The touchpad will respond to a light touch from your fingertip.

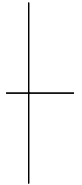

Click, Double-click, and Right-click

To click or double-click, you can use the left button just like that of a mouse. Instead of clicking the left button, you can also just tap gently anywhere on the rectangular pad. For right-clicking, you must use the right button.



If the interval between clicks is too long, the double-click will not function.

Drag and Drop

You can move the items by using “drag and drop” below:

1. Position the pointer over the item you wish to move.
2. Press the left button; do not release it.

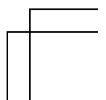
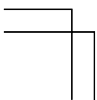

3. Move the pointer while holding the left button. The item moves together with the pointer.
 4. Release the button when the item reaches its destination.
- Or you can tap the pad twice and hold it instead of pressing the left button in the step 2.

Scroll

You can scroll through information in a list or in a document by using the touchpad. To view information vertically, place your finger on the most right part of the touchpad and slide your finger up and down. To view horizontally, place your finger on the bottom part of the touchpad and slide your finger to the left or the right. This procedure works only in limited applications.

1

Changing Configuration

In the *Mouse Properties* dialog box, you can change the configuration of the touchpad, such as swapping left and right buttons, changing the pointer size, etc. Double-click  icon on the taskbar.

Using Keyboard

The computer, equipped with the Windows Enhanced Keyboard, provides all the functionality of a full-sized desktop keyboard.

Special Keys



Windows Key

Opens the Windows start menu. This key works in the same way as the *start* button on the screen.





Application Key

Opens short-cut menus for the specific items. This key works in the same as the right mouse button.

System Function Keys





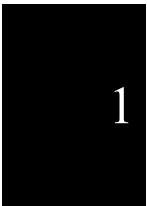
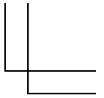
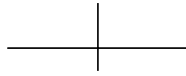

Your keyboard contains the function keys labeled **F1** through **F12** for special actions. Use them in conjunction with **Fn** key.

Fn + F1 () Turns the wireless LAN antennas on and off

Fn + F3 () Decreases the audio volume

Fn + F4 () Increases the audio volume



- Fn + F5 () Rotates display mode among LCD only, an external monitor only, and both (when connecting an external monitor)
- Fn + F6 () Decreases the LCD screen brightness
- Fn + F7 () Increases the LCD screen brightness
- Fn + F8 () Maximizes the LCD screen brightness
Returns to the previous status by pressing them again
- Fn + F11 () Turns the LCD screen on and off
- Fn + F12 () Forces the computer into System standby, hibernate, or powered off
(See *Power Management* of Chapter 2 for more information.)

Using Optical Drive

The computer is equipped with an optical drive allowing you to read from DVD and CD and write onto CD-R/RW.



CAUTION FOR LASER

Use of controls or adjustments or performance of procedures other than those specified herein may result in hazardous radiation exposure.



Handling Disc

- Do not write on either side of the disc, particularly the non-label side. Data is read/write from/onto the non-label side. Do not mark this surface.
- Keep your discs away from direct sunlight, heat and excessive moisture.
- Always hold the discs by the edges. Fingerprints, dirt or water on the discs can cause noise or mistracking. If a disc is dirty or does not play properly, clean it with a soft, dry cloth, wiping straight out from the center, along the radius.

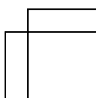

Inserting Disc

1. Make sure the optical drive indicator is off; then, press the eject button. The drive tray will pop out.

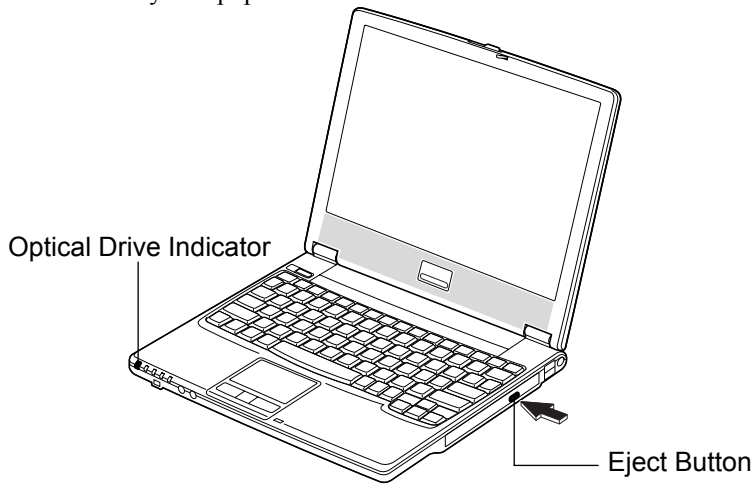

2. Gently pull out the tray.

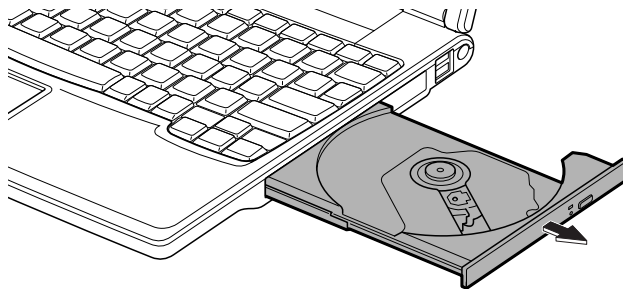

3. Place your disc, label side up, onto the tray and slightly press the center of the disc until it locks into place.

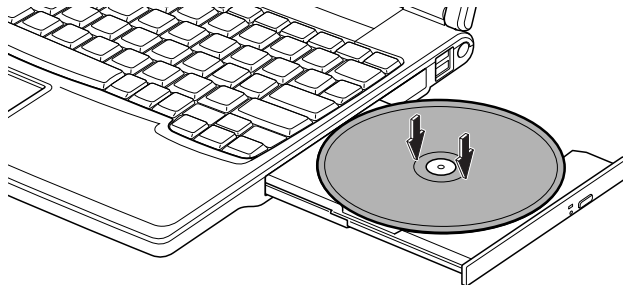

4. Gently push the tray back into the computer.

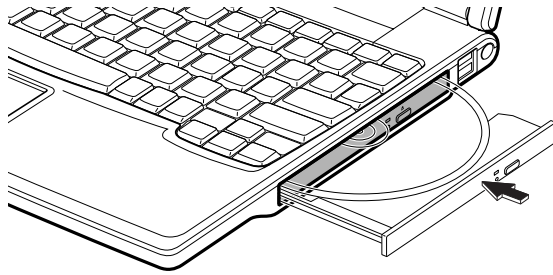

- *Do not press the eject button when the optical drive indicator is lit. It may cause malfunction of the computer.*
- *Do not leave the tray pulled out. Also, avoid touching the lens in the tray. If the lens becomes dirty, the disc may malfunction.*

Removing Disc

1. Make sure the optical drive indicator is not lit and press the eject button. The optical drive tray will pop out.



Make sure the optical drive indicator is not lit before pressing the eject button.

2. Gently pull out the tray.
3. Remove the disc from the tray by holding its edge.

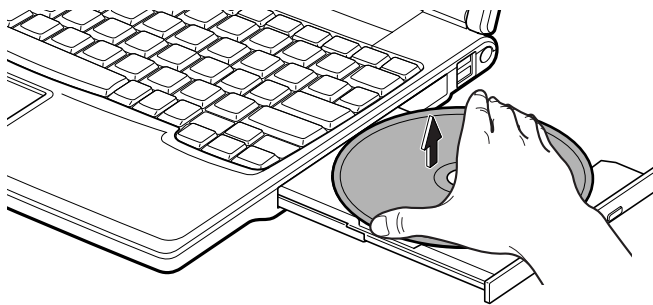

4. Gently push the tray back into the computer.

Writing Data to Disc



- *Before writing to discs, follow the instructions below:*
 - *Connect the AC adapter. If the battery is discharged, writing process will stop and fail.*
 - *Disable the power management. See the Power Management of Chapter 2.*
 - *Close all of the unnecessary or the automatic start-up applications.*
 - *Disable the screen saver. (Refer to the Changing Wallpaper and Setting Screen Saver section later in this chapter.)*
- *Some discs restrict the writing or rewriting speed to ensure recording quality.*
- *When copying data with an installed application, Drag'n Drop CD+DVD, the type of the destination media should be same as that of the source media.*
- *After creating an audio CD, you cannot add data into it even if it is not full.*

1

You can use CD-R or CD-RW discs to write data on. CD-RW discs are erasable, which means that you can write and erase repeatedly. CD-R discs are non-erasable disc, which means that you can write data only once. If free space remains, you can add data until the disc is full.

To write data, use the preinstalled application, Drag'n Drop CD+DVD.

To run the Drag'n Drop CD+DVD, click *start – All Programs – Drag'n Drop CD+DVD4 – Drag'n Drop CD+DVD4*. (Refer to the online help of the Drag'n Drop CD+DVD for more information.)



- *See the online help of the Drag'n Drop CD+DVD for details and other features.*
- *You can also write data with the Windows CD writing software on the computer. Refer to the Windows Help and Support for more information.*

Watching DVD Video

You can watch DVD videos using the application called WinDVD. See online help of WinDVD for more details.

To run the application, click *start – All Programs – InterVideo WinDVD - InterVideo WinDVD*.

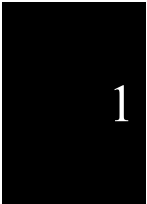
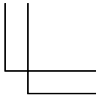
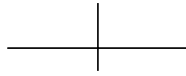

- When you run WinDVD for the first time, you need to enter the serial number on the bottom of the computer.
- Before watching DVD videos, follow the instructions below:
 - Connect the AC adapter. If the battery is discharged, the operation will stop.
 - Disable the power management. See the Power Management of Chapter 2.
 - Close all of the unnecessary or the automatic start-up applications.
 - Disable the screen saver. (Refer to the Changing Wallpaper and Setting Screen Saver section later in this chapter.)
- When playing a DVD video, you may experience a picture with an irregular motion, or frame dropouts, depending on videos.



Make sure to remove the DVD video from the drive when you finish watching it. If you turn off the computer with the disc left in the drive, the drive may not be recognized when the computer is turned on again.

Changing Region Code

A DVD video has a region code which prevents playback of the disc in certain regions. The region code appears on the top of the disc.

When shipped from the factory, your optical drive is set to a region code applicable to your area.



Your DVD drive region code can be changed. Code change is limited. Once the limit is reached, it cannot be changed any more. To confirm the limit, click Region tab of Setup dialog box and check the bottom line in the window. (Refer to the Using Parental Control section on the next page to open the Setup dialog box.)



Make sure to log on the computer as a member of the Computer administrators group. Otherwise you cannot change the region code.

Available region codes are:

Region Code	Area
1	U.S.A, Canada
2	West Europe, Japan, South Africa
3	South East Asia (including Hong Kong)
4	Australia, Spanish America
5	Former Soviet Union, Indian Subcontinent, Africa
6	China

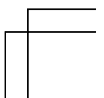

To change the region code:

1. Insert a DVD video into the drive.
If the region code of the DVD video is different from that of your drive, the *Confirm Region* dialog box appears.
2. The region code currently selected is checked in the left box. Region code of your DVD video is marked in the right box. If you want to change the drive code and play the DVD video, click *OK*.



On some DVD videos, plural region codes are selectable in the right box of Confirm Region dialog box. Carefully choose an appropriate one.



When Confirm Region dialog box does not appear:

1. Click start - My Computer – View system information.
2. In the System Properties dialog box, select the Hardware tab and click the Device Manager button.
3. In the Device Manager dialog box, double-click DVD/CD-ROM drives *string and MATSHITA xxxxxx*. (*xxxxxx is your optical drive name.*)
4. Select the DVD Region tab, choose the listed distribution area of the DVD video, then, confirm the region code shown in the New Region field is correct and click *OK*.
5. Read the message on the screen, then, click *OK*.

Using Parental Control

If you want to set the parental control to prevent your children from watching an inappropriate movie, follow the steps below:

1. Run the *InterVideo WinDVD*.
2. Right-click somewhere in the *InterVideo WinDVD5* window and click *Setup....*
The *Setup* dialog box will appear.
3. In the *Preferences* tab, click the *Set Password* button in the *Parental Playback Control* section.
4. Type a password twice and click *OK*.
5. Click *OK* in the confirmation window.
6. Click the *Set Rating* button and enter the password.
7. Click *OK*.
8. Select a control level and click *Set*.
9. Click *OK*. See online help of *WinDVD* for more details.

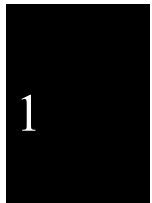

Controlling Volume

You can adjust the output volume of the computer with the following volume controls that interact with each other.

With Keyboard

Press and hold **Fn** key and then, press **F3** () key to decrease the output volume. Press and hold **Fn** key and then, press **F4** () key to increase the output volume.



These functions do not work in MS-DOS mode.

On Windows

1. Click *start - Control Panel*.
2. Click *Sounds, Speech, and Audio Devices*; then, *Sounds and Audio Devices*. If the Classic view is selected, double-click the *Sounds and Audio Devices* icon.
3. In the *Sounds and Audio Devices Properties* dialog box, slide the lever to control the output volume.
4. Click *OK* and close the dialog box; then the *Control Panel* window.



You can also easily adjust the volume in the window that will open when you click the speaker symbol on the taskbar. If the symbol is not on the taskbar, check the box of Place volume icon in the taskbar in the step 3.

Adjusting Display

You can adjust the brightness, resolution, and number of colors of the internal LCD display for more comfortable viewing.

Changing Brightness of Display

Press and hold **Fn** key and then, press **F6** () key to decrease the brightness of the internal LCD display.

Press and hold **Fn** key and then, press **F7** () to increase the brightness of the internal LCD display.

Press and hold **Fn** key and then, press **F8** () to maximizes the LCD screen brightness. Pressing them again returns the LCD screen brightness to the previous status.

1

Changing Resolution and Number of Colors

When shipped, the computer is set to the default resolution and color. The default resolution is 1024 x 768 at 64K colors. To change the resolution and the number of colors, follow the instructions below:

1. In the *Display Properties* dialog box, select the *Settings* tab.
2. Select the number of the colors in the *Color quality*, and select the resolution in the *Screen resolution*. Refer to the table bellow.
3. Click *OK*; then, *Yes*.

Available Resolutions and Colors

Resolution	Number of Colors
800 x 600	64K 16M ^(*2)
1024 x 768	64K 16M ^(*2)
1280 x 1024 ^(*1)	64K 16M
1600 x 1200 ^(*1)	64K 16M

(*1) Can be chosen for an external monitor only when it is capable of the listed resolution modes. Cannot be set when displaying only on the LCD monitor or on both of the LCD and an external monitor simultaneously.

(*2) On the internal LCD screen, the number of colors in this mode is made using a Dithering algorithm.



- You cannot switch to display resolutions and number of colors that are not available.
- In the Color quality, Medium (16 bit) means 65,536 (64K) colors, and High (24 bit) means about 16,770,000 (16M) colors.
- If you select High;
 - Drawing speed may be delayed.
 - When playing animation, the screen may be distorted.

1

Changing Wallpaper and Setting Screen Saver

You can enjoy various desktop patterns or screen savers.

Changing Wallpaper

1. In the *Display Properties* dialog box, select the *Desktop* tab.
2. Select appropriate wallpaper in the *Background* field.
3. Click *OK*.

Setting Screen Saver

1. In the *Display Properties* dialog box, select the *Screen Saver* tab.
2. Select an appropriate screen saver in the *Screen saver* field and set time when screen saver starts.
3. Click *OK*.



To disable the screen saver, select [None] from the Screen saver pull-down menu.

Sharing Your Computer

If you are sharing the computer with your colleagues or family members, set a user account for each person. Every user can choose their favorite desktop setting, web site lists, or make their own *My Documents* folder etc., and save them to their user accounts. When you turn on the computer, select your user account.

Setting New User Account

1. Click *start - Control Panel*.
2. Click *User Accounts*. If Classic view is selected, double-click the *User Accounts* icon.
3. Click the *Create a new account* string.
4. Type a name for the new account and click *Next*.
5. Select the account type; then, click *Create Account*. If you have selected a *Limited* account, then that user account has limits for using the computer. See *Help and Support Center* in *start* menu for more details.
6. Close the *User Accounts* dialog box; then, the *Control Panel* window.

If more than one user account are set to the computer, you must select which user account you will log in when you turn on the computer.

Log Off Your Computer

“Log off” is useful because you do not have to turn off the computer when you finish your task and pass the computer to another person. There are two ways to log off the computer, *Switch User* or *Log Off*.

If you select *Switch User*, you can pass the computer to another person without closing your current applications. For example, if you are viewing a Web site, and your colleague needs to open a program on the computer, use *Switch User*. You can then view the same Web site by just switching users after your colleague finishes with the computer.

If you select *Log Off*, the system will close all your session and you need to save your files before logging off the computer.

1. Click *start - Log Off*.
2. Select *Switch User* or *Log Off*. If you select *Log Off*, the dialog box, which asks you to save your data, may appear.

3. Select a new account to start Windows again.



If you cannot see Switch User in the Log Off Windows dialog box, click the Change the way users log on or off string in the User Accounts dialog box, and check Use Fast User Switching and click Apply Options.

1

Setting Password to User Account

You can set a password to each user account to avoid unauthorized use of the computer. Once you set the password, you need to enter it when you log on to its account. You cannot start the computer with the user account if its password is not correct, so unnecessary password setting can cause trouble in starting the system.

Setting Password

1. Click *start - Control Panel*.
2. Click *User Accounts*. If the Classic view is selected, double-click the *User Accounts* icon.
3. Select the account you want to set a password to. You will only have this option if you log onto the computer as a member of the Computer administrators group. If you log on the computer with a limited user account, go to the next step. (You cannot set a password to another user account.)
4. Select the *Create a password* string.



- *If the password has been already set, Create a password will not appear.*
- *Only the members of the Computer administrators group can set a password to another user account.*

5. Type a new password.
6. Type the new password again to confirm it.
7. If necessary, type a password hints word to remember the password you set.
8. Click *Create Password*.
9. Close the *User Accounts* dialog box; then, the *Control Panel* window.

Changing Password

1. Follow the steps 1-2 on the previous section.
2. Select the account you want to change, if you log on to the computer as a member of the Computer administrators group. If you log on the computer with a limited account, go to the next step. (You cannot change the password of another user account.)
3. Select the *Change the password* string or the *Change my password* string.



- *If the password has not been set yet, Change the password or Change my password will not appear.*
- *Only the members of the Computer administrators group can change the password of another user account.*

4. Type the current password. If you are changing another user's password, skip this step.
5. Type a new password.
6. Type the new password again to confirm it.
7. If necessary, type a password hints word to remember the password you set.
8. Click *Change Password*.
9. Close the *User Accounts* dialog box; then, the *Control Panel* window.

Deleting Password

1. Follow the steps 1-2 on the *Setting Password*.
2. Select the account you want to delete its password, if you log on to the computer as a member of the Computer administrators group. If you log on the computer with a limited account, go to the next step. (You cannot delete the password of another user account.)
3. Select *Remove the password* string or *Remove my password* string.



- *If the password has not been set yet, Remove the password or Remove my password will not appear.*
- *Only the members of the Computer administrators group can delete the password of another user account.*

4. Type your password and click *Remove Password*. If you log on to the computer as a member of the Computer administrators group and want to delete the password of another user account, just click *Remove Password*.
5. Close the *User Accounts* dialog box; then, the *Control Panel* window.

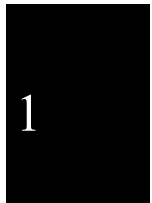

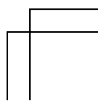
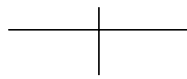
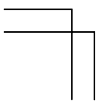
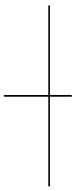
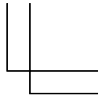
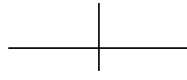
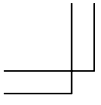

CHAPTER 2

Battery and Power Management

This chapter explains how to manage the computer's power effectively and use the battery pack.



In this section, you often see the expression “Power Options Properties dialog box”. To open the dialog box:

1. *Click start – Control Panel.*
2. *Click Performance and Maintenance – Power Options in the Category view or double-click the Power Options icon in the Classic view.*

2

Battery Pack

When not connected to an external power source, the computer operates with the rechargeable battery pack. The duration of the battery life may be longer if the computer's power management is active. See the *Power Management* section in this chapter for the power management.

To keep the battery life longer:

- Condition the battery pack if the actual remaining power in your battery is less than what the Windows *Power Meter* indicates. (See the *Conditioning Battery Pack* section in this chapter.)
- Turn off the computer when you are not using it.



- *The duration of the battery depends on the computer usage. Using applications, which heavily use external peripherals, will result in shorter battery life.*
- *When using the computer for several hours with battery power, enable power management and set the system hibernate. Refer to the Power Management section in this chapter.*
- *When the battery has not been charged, the computer may not operate properly. Connect the AC power source to charge the battery.*

Charging Battery Pack

1. Connect the AC adapter to the computer. While the battery is being charged, the battery indicator lights orange.
2. When the battery is fully charged, the battery indicator turns green. Charging time may vary according to the status of the computer.





2



- *The battery indicator may turn off even while the battery is being charged. This is because the battery pack is hot, and the charging stops temporarily. When the battery becomes cool, the charging will start and the battery indicator will turn on again.*
- *When the battery is deep discharged, it may not be charged when the computer is powered on. In this case, charge the battery pack with the power off.*
- *When the power consumption is high, the indicator may turn off.*
- *The battery pack may not be installed correctly if the battery indicator blinks orange. In this case, turn off the computer, remove the AC adapter and the battery pack; then, install the battery pack and connect the AC adapter again. If the battery indicator still blinks orange, ask your local dealer for assistance.*
- *When the battery pack is hot (for example, after a long use), it may take longer to be fully charged.*

Checking Battery Level

On Windows

You can check the battery level by placing the pointer on the battery icon ( : powered on battery) or the AC plug icon ( : powered on AC power and charging the battery pack) on the taskbar, or double-clicking one of these icons (,  or  : powered on AC power) to open the *Power Meter* dialog box. If the battery is fully charged, remaining capacity level will not appear even if you point to the icon.

If you cannot see the battery or AC plug icon, follow these instructions:

1. In the *Power Options Properties* dialog box, select the *Advanced* tab.
2. Check the box of *Always show icon on the taskbar* and click *OK*.
3. Close the *Control Panel* window.



- *The remaining operating time depends on the amount of the power the computer is consuming. If you are using the audio system, PC card slot, hard disk drive, or peripheral devices with the computer, it may consume more battery power.*

- The Power Meter may not indicate correctly for a short period after resuming from standby or hibernation mode.
- If the actual remaining power in your battery is less than what the Power Meter indicates, you should condition the battery pack as per the procedure on the Conditioning Battery Pack section in this chapter.

Low Battery Indication

On Windows, you can set the battery level for sounding an alarm and letting the computer go on System standby, System hibernate or shut down.



When the battery power level becomes significantly low, the battery indicator (🔋) blinks red and the warning beep sounds. Save your data and turn off the computer, or connect the AC power source immediately. Otherwise, the computer will be shut down and the unsaved data may be lost.

2

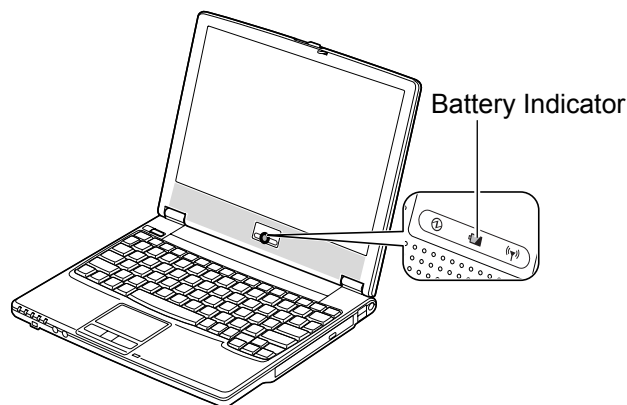

1. In the *Power Options Properties* dialog box, select the *Alarms* tab.
2. Set the battery level at which the alarms are activated. We recommend you set the *Critical battery alarm* to 5% or more and the *Low battery alarm* to more than the value of the *Critical battery alarm*.
3. Set the *Alarm Action...* to the appropriate settings.
4. Click *OK* twice.
5. Close the *Control Panel* window.

Conditioning Battery Pack

Conditioning the battery pack is needed when the actual remaining power in your battery is less than what the Windows Power Meter indicates, or you buy a new battery pack.

1. Make sure the computer is turned off.
2. Connect the computer to AC power and wait until the battery is fully charged.

2



The battery indicator turns orange first; then, turns to green when the battery pack is fully charged.

3. Turn on the computer.
4. When the message <F2> to enter System Configuration Utility appears, press **F2** to open the Setup Utility.
5. Disconnect the AC adapter, and leave the computer on until the battery is completely discharged and the system shuts down automatically.
6. Connect the computer to AC power and let the battery fully charged again.



- Do not turn on the computer until the battery indicator turns to green and the battery is fully charged.
- Do not connect the computer to AC power while discharging the battery. The conditioning will be cancelled.



Repeated charging and discharging or long-term storage of the battery pack cause battery deterioration. In this case, replace the battery pack with a new one.

Changing Battery Pack

The capacity of a battery pack gradually decreases when used repeatedly (the deterioration rate depends on the operating environment). If the battery life becomes extremely short even after the conditioning, you should buy a new battery pack. Consult your local dealer for a new battery pack.

When you replace the battery pack with a new one:

1. Turn off the computer and disconnect the AC adapter from the computer.
2. Close the display cover and turn over the computer on a flat place.

3. Slide the two battery stoppers to the unlocked position (🔓) and hold them; then, push out the battery pack.

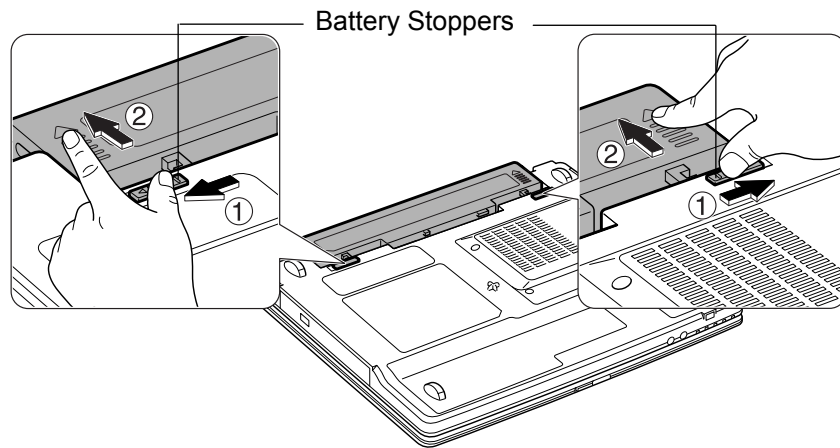

2

4. Insert the new battery pack into the computer by matching the notched part of the battery to the projected parts of the computer.

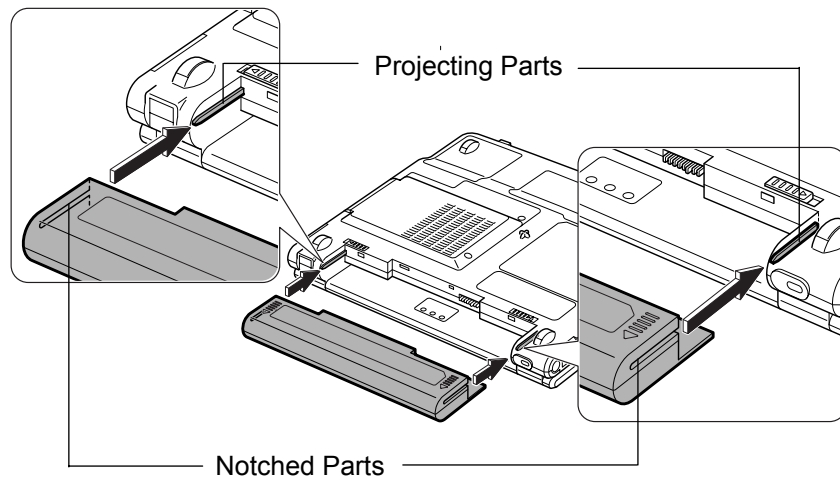

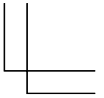

5. When the battery is properly inserted, you will hear the click sound and the levers go back to their original positions.

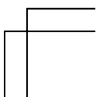
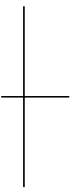
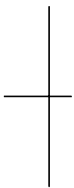
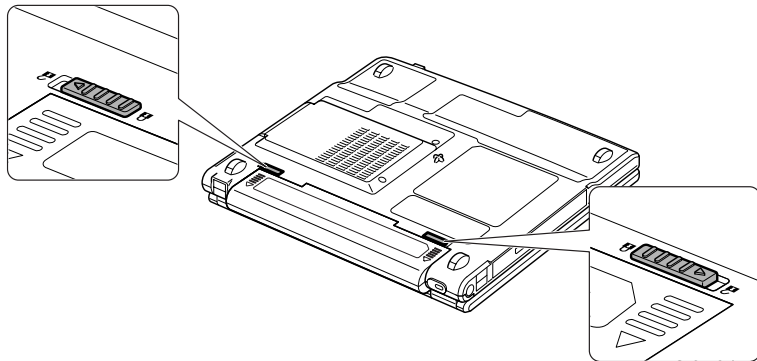

Power Management

Power management saves electricity and extends battery life by controlling power supply to built-in devices. You can set the following power management properties on Windows.

- Stopping power supply to the hard disk
- Stopping power supply to the display
- Controlling CPU speed
- Using System standby/hibernate

2

To open the *Power Options Properties* dialog box, click *start – Control Panel*, and click *Performance and Maintenance*; then, *Power Options*. If the Classic view is selected, double-click the *Power Options* icon.



Note that the power management may not seem to function when you are using an application program that accesses the hard disk periodically.

Stopping Power Supply to Hard Disk

1. In the *Power Options Properties* dialog box, select the *Power Schemes* tab.
2. Set *Turn off hard disks* to an appropriate value, and click *OK*.
3. Close the *Control Panel* window.

Stopping Power Supply to Display



This procedure is also available for an attached external monitor complying with the power management.

1. In the *Power Options Properties* dialog box, select the *Power Schemes* tab.
2. Set *Turn off monitor* to an appropriate value, and click *OK*.
3. Close the *Control Panel* window.

Controlling CPU Speed

Windows XP controls the processor performance to reduce power consumption.



While communicating or reading/writing data, do not control the Processor Performance or connect/disconnect the AC adapter. Otherwise the computer may malfunction.

2

1. In the *Power Options Properties* dialog box, selected the *Power Schemes* tab.
2. Select an appropriate power scheme from the pull-down menu in the *Power schemes* field according to the table below, and click *OK*.
3. Close the *Power Options Properties* dialog box, then, the *Control Panel* window.

Power Scheme	Processor Performance	
Home/Office Desk	Using AC Power	Always runs at highest performance state
	Using Battery	Performance state will be chosen based on CPU demand
Portable/Laptop	Using AC Power	Performance state will be chosen based on CPU demand
	Using Battery	Performance state will be chosen based on CPU demand
Presentation	Using AC Power	Performance state will be chosen based on CPU demand
	Using Battery	Always runs at lower performance state
Always On	Using AC Power	Always runs at highest performance state
	Using Battery	Always runs at highest performance state
Minimal Power Management	Using AC Power	Performance state will be chosen based on CPU demand
	Using Battery	Performance state will be chosen based on CPU demand
Max Battery	Using AC Power	Performance state will be chosen based on CPU demand
	Using Battery	Always runs at lower performance state



- *Note that Power schemes includes other power management settings (such as a timer for System standby, etc.) appearing on the Power Schemes tab. Confirm those settings are set to an appropriate value when you select the processor performance using power schemes facility.*
- *You can set your own Power scheme. Set all power management settings to your suitable ones, and click Save as...; then, type an appropriate name and click OK.*
- *Once the preinstalled Power scheme settings listed on the previous page are deleted, there is no way but re-installation to resume them.*

Using System Standby/Hibernate

System standby/hibernate is a very useful power management tool. For example, after the computer has entered the system standby mode, you can restart the computer more quickly when compared to restarting after a normal shutdown operation. When the computer resumes from the system standby/hibernate, the system restores the exact last state of the computer. In Windows, the *System standby* and *System hibernate* are defined as following:

- *System standby* stores the current condition of the computer in RAM and stops power supply to all but a few essential components. Your system enters and resumes from the system standby per the conditions mentioned later. In the system standby, the power indicator blinks green and the power button blinks blue. To resume from the system standby, press any key.
- *System hibernate* saves the current condition of the computer in part of the hard disk and turns off the computer. Your system enters and resumes from the system hibernate per the conditions mentioned later. In the system hibernate the power indicator is off. To resume from the system hibernate, press the power button.



While the computer is entering/resuming from the system standby/hibernate, follow these instructions:

- *Finish communications, printing, and playing music or video before the computer enters the system standby/hibernate.*
 - *Do not operate the computer or peripheral devices, or connect/disconnect peripheral devices.*
 - *Save your data before the computer enters the system standby. If the power supply to the computer is stopped, the RAM contents will be lost.*
-



Select your user account if Windows requires when the computer resumes from the system standby/hibernate.

Supporting System Hibernate



If your battery becomes completely discharged during the system standby, you will lose unsaved data and will need to reboot the computer. Therefore, if you are planning to leave the computer powered by battery for long periods of time, we recommend the system hibernate.

2

Confirm that the system hibernate is supported with the following steps.

1. In the *Power Options Properties* dialog box, select the *Hibernate* tab.
2. Confirm the box of *Enable hibernation* is checked.
3. Click *OK*.
4. Close the *Control Panel* window.

Set Timer to Enter System Standby/Hibernate Automatically



The computer will enter the system standby/hibernate automatically when the specified time has passed without any operation. To set the time:

1. In the *Power Options Properties* dialog box, select the *Power Schemes* tab.
2. From the pull-down menu of the *System standby* or/and *System hibernates*, select the elapsed time before the computer automatically enters the system standby/hibernate.
3. Click *OK*.
4. Close the *Control Panel* window.

Entering System Standby/Hibernate

The computer enters the system standby/hibernate in each of the following cases:

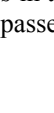
- You select Stand By or Hibernate (which will replace *Stand By* if your press **Shift** key) in the *Turn off computer* dialog box. To open the dialog box, click *start – Turn Off Computer*.

- The specified time in the *System Standby* or *System hibernates* in the *Power Schemes* tab of the *Power Options Properties* dialog box has passed without any operation. (See the previous section.)
 - The screen cover is closed.
The above functions if you perform the following:
 1. In the *Power Options Properties* dialog box, select the *Advanced* tab.
 2. Select *Hibernate* or *Stand by* in the *When I close the lid of my portable computer* field.
 3. Click *OK*.
 4. Close the *Control Panel* window.
 - You press the power button.
The above functions if you perform the following:
 1. In the *Power Options Properties* dialog box, select the *Advanced* tab.
 2. Select *Hibernate* or *Stand by* in the *When I press the power button on my computer* field.
 3. Click *OK*.
 4. Close the *Control Panel* window.
 - You press the **Fn+F12** ()
The above functions if you perform the following:
 1. In the *Power Options Properties* dialog box, select the *Advanced* tab.
 2. Select *Hibernate* or *Stand by* in the *When I press the sleep button on my computer* field.
 3. Click *OK*.
 4. Close the *Control Panel* window.
-  *If Ask me what to do is selected in the step 2 of You press the power button or You press **Fn+F12** () , the Turn off computer dialog box will appear when you press the power button or the **Fn+F12** () key combination. You can select System standby or System hibernate at that timing.*
- The battery level is low.
The above functions if you set the alarm in Windows. See the *Low Battery Indication* section earlier in this chapter.

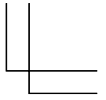
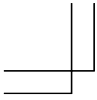

Disabling Power Management

1. In the *Power Options Properties* dialog box, select the *Power Schemes* tab.
2. Set *Turn off monitor*, *Turn off hard disks*, *System standby*, and *System hibernates* to *Never*, then, click *OK*.
3. Close the *Control Panel* window.



2

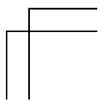
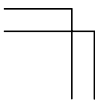
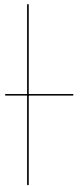
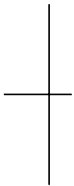

CHAPTER 3

Peripherals

This chapter describes how to use peripheral devices with the computer. You can connect an optional floppy disk drive unit, a printer, an external monitor, a PC card, or other devices to the computer. To ensure proper use, be sure to read the instructions for each peripheral device before connecting it to the computer.

Peripheral Device Ports

3

The computer has connection ports for the peripheral devices shown on the next page. For connection, refer to the section explaining each device, or contact your dealer.







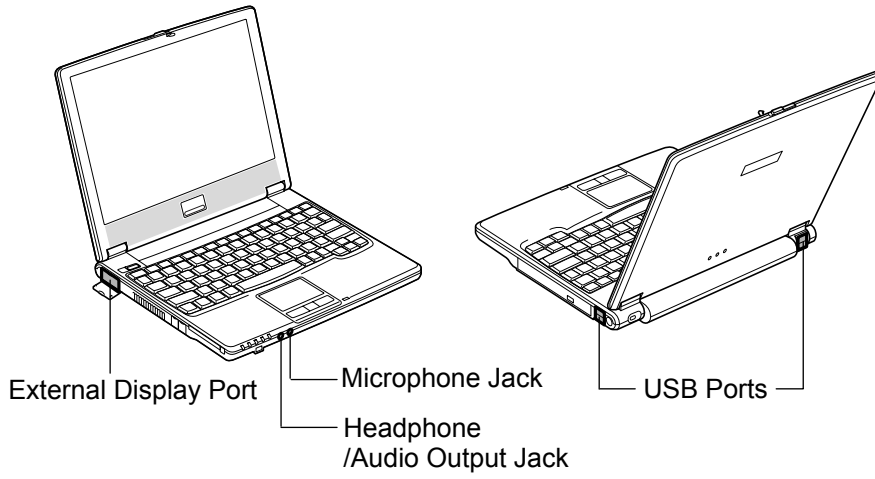

- *Be sure to turn off the computer and the peripheral devices before connecting them (except a USB device, a PC card, etc).*
- *Confirm the peripheral devices you will connect are Windows XP compatible.*
- *When you connect some of the devices, you may have to turn on the computer before powering on the devices.*
- *Some devices require that you install the appropriate drivers before use.*

Connection Ports for Peripherals

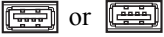
3



Port Design

Port name	Port Design
USB Port	 or 
External Display Port	  
Headphone / Audio Output Jack	
Microphone Jack	

Optional External Floppy Disk Drive Unit

You can use high-density (2HD) 1.44MB or double-density (2DD) 720KB floppy disks with the optional external floppy disk drive unit (CE-FD05).



- 1.44MB (2HD) disks are appropriate for the drive unit.
- There are restrictions in using 720KB (2DD) disks. Refer to the Trouble with Floppy Disks section in the Troubleshooting in this manual.

Connecting Optional External Floppy Disk Drive Unit

3



- Do not place the floppy disk drive unit on its side or upside down.
- Do not press on the floppy disk drive unit. It may damage the drive or cause malfunction.
- Do not place the AC adapter on the floppy disk drive unit. It may cause the drive to malfunction.

Connect the floppy disk drive unit cable to one of the USB ports on the computer.



When connecting the cable to one either of the USB ports on the right face of the computer, be sure to let the USB mark (↔) face upward, and when using ones on the rear face, let it downward.

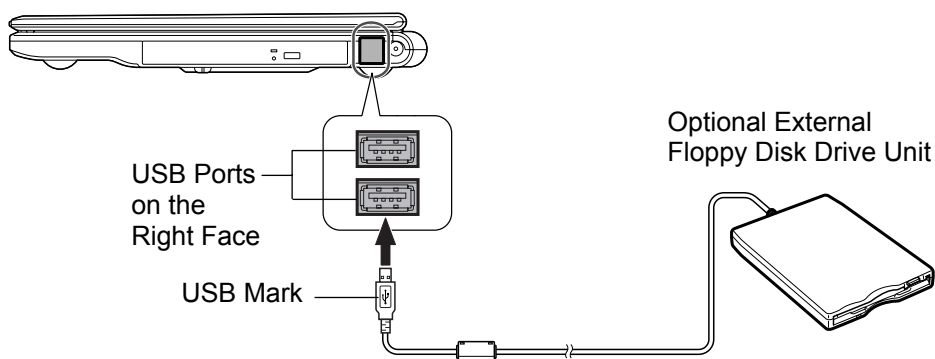

Handling Floppy Disk

- Do not open the shutter and touch the disk inside; otherwise, you will not be able to read or write data to the disk.
- Do not place floppy disks near magnets or heat source, in direct sunlight or in a dusty place, etc.
- Never subject a disk to sudden shocks or extreme vibration. Do not drop, bend, or place heavy objects on a disk.
- Do not spill liquid onto a disk.

3

Inserting Floppy Disk

Hold the floppy disk with the arrow facing upward, toward the drive. Slide the disk into the drive until it locks into place.

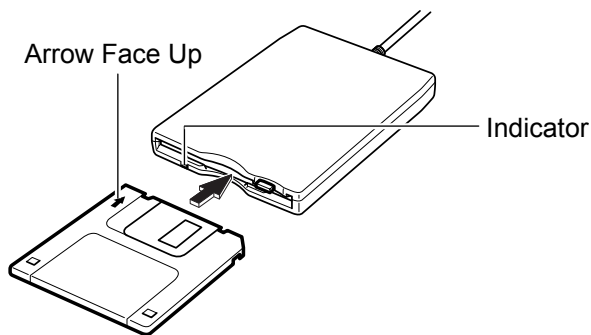

- *Always insert a floppy disk straight into the floppy disk drive.*
 - *When inserting the disk, make sure it is not upside down.*
 - *Do not use excessive force when inserting the floppy disk. If you have difficulty inserting or removing a disk, consult an authorized service technician.*
 - *Do not touch the disk while reading/writing data. It may cause malfunction of the computer and the drive.*
-

Ejecting Floppy Disk



Before ejecting the floppy disk, make sure the indicator of the floppy disk drive unit is off.

1. Press the eject button firmly. The disk pops out slightly.
2. Eject it and store it properly.

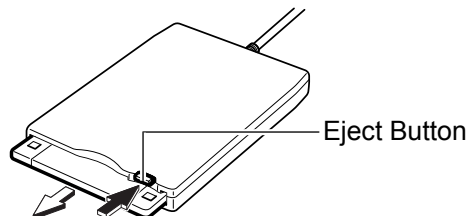

Formatting Floppy Disk

1. Make sure the floppy disk is not write-protected, and insert it into the floppy disk drive.
2. Click *start – My Computer*.
3. Right-click *3 1/2 Floppy (A:)* icon; then, click *Format...* from the pop-up menu.
4. Select the appropriate formatting options.
5. Click *Start* to start formatting.



- *When you format a floppy disk that already contains data, all of the data stored on the disk will be lost.*
 - *You cannot format double-density (2DD) floppy disks.*
-

Removing Optional External Floppy Disk Drive Unit

- To remove the unit, you need to perform the following steps before you remove it.
1. Click the *Safely Remove Hardware* icon () on the taskbar.
 2. Click *Safely remove Mitsumi USB Floppy – Drive(A:)*; then, *Safe To Remove Hardware* dialog appears.
 3. Remove the unit from the computer.

External Display

You can use an external monitor with the computer. To display the images on both displays simultaneously, use the 1024x768 resolution.



- *Some monitors, which are not compatible with the computer, may not display correctly.*
- *In this section, you often see the expression “Display Properties dialog box.” To open the dialog box, right-click somewhere on the Windows desktop and select Properties from the pop-up menu.*
- *To display the image on an external monitor, you may need to install its driver. Before using the external monitor, refer to the manual included with it.*

3

Connecting External Monitor

1. Turn off the computer and the external monitor.
2. Open the external display port cover.

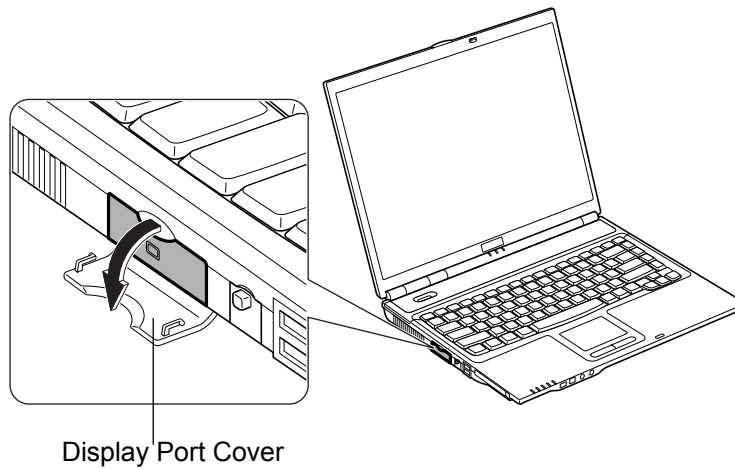

Be sure to close the display port cover when the external display port is not used.

3. Connect one end of the display cable to the external display port, then, the other end of the display cable to your external monitor. If the display cable has screws, be sure to tighten them.

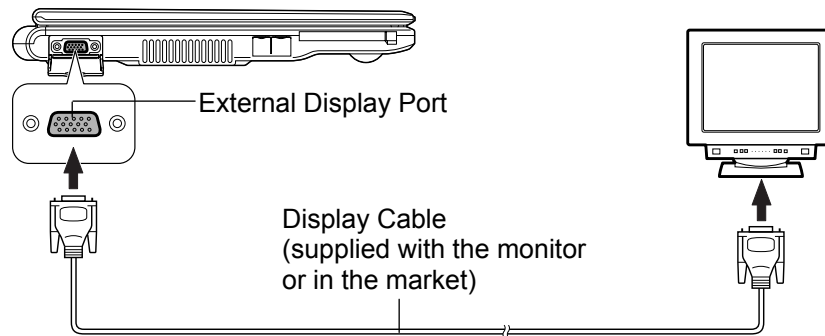



4. Turn on the external monitor; then, the computer.

Switching Display

1. In the *Display Properties* dialog box, select the *Settings* tab; then, click the *Advanced* button.
2. Select the *S3Display* tab; then, check the box of the desired output display(s) and click *OK*.
3. Click *OK* in the confirmation window.
4. Click *Yes* in the confirmation window.
5. Click *OK* and then, close the dialog box.



- You can also switch the display with the **Fn+F5** () keys.
- While you are logging on the computer as a member of the *Limited group*, the dialog box is not available for switching. Use the **Fn+F5** () keys.
- While playing video or animation, you may not be able to switch the display.

Disconnecting External Monitor

1. Turn off the computer and the external monitor.
2. Remove the display cable from the computer.
3. Close the display port cover.

Audio System

You can output sound to speakers, audio equipment or headphones and also input sound through a microphone.

Connecting Speaker

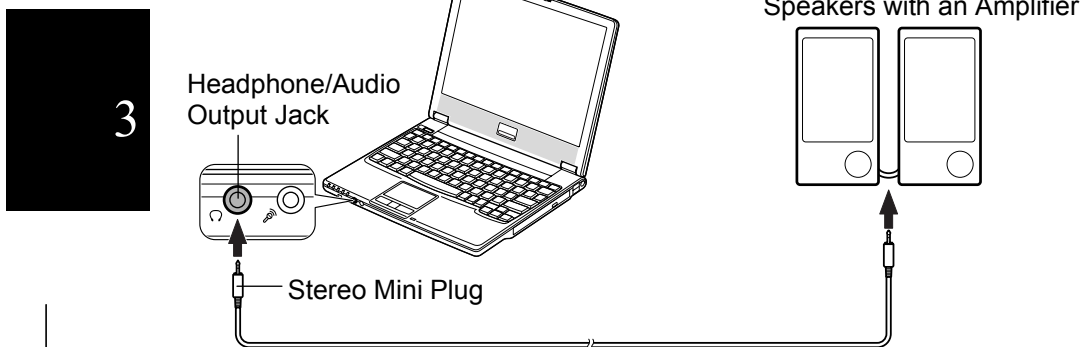

You can connect stereo speakers with an amplifier to the audio output jack on the computer.

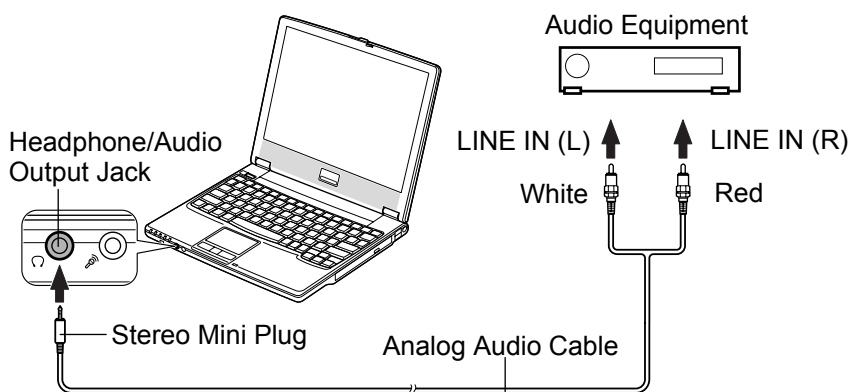

Connecting Audio Equipment

You can connect analog audio equipment to the audio output jack on the computer.



*You can adjust the output volume on Windows by clicking the speaker symbol on the taskbar or use the **Fn+F3** () or **F4** () keys combination.*

Connecting Headphone

Use the headphone with an impedance of 8Ω or more. (32Ω is recommended.)

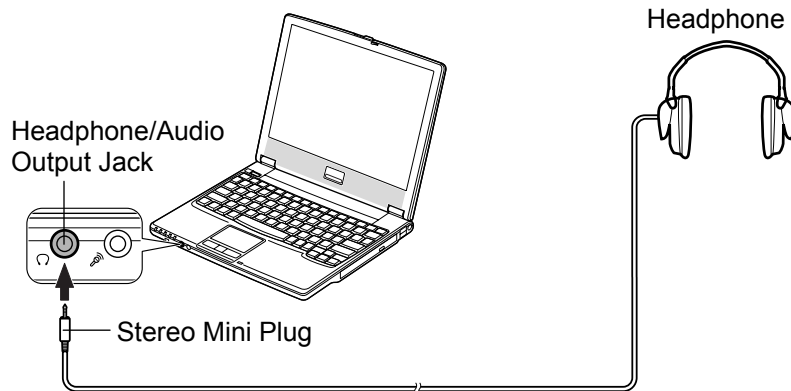

Connecting Microphone

You can input sound using an external microphone connected to the microphone jack. Use an electret condenser microphone with an impedance of $1.5k\Omega$ through $2.4k\Omega$ and an allowable voltage of $2.5V$.

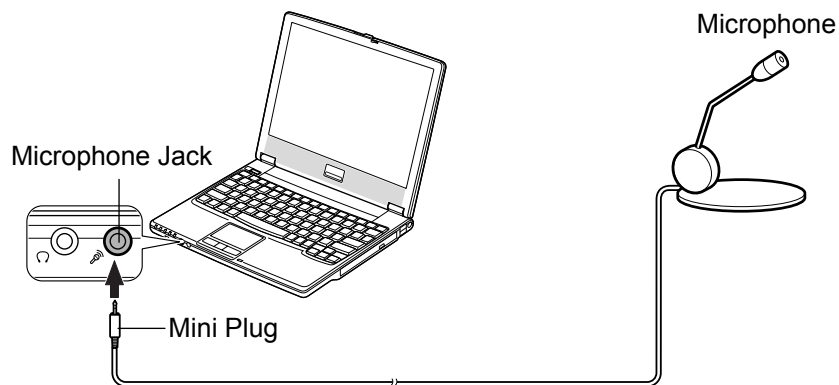

To record sound:

1. Click *start*; then, point *All Programs – Accessories – Entertainment*.
2. Click *Sound Recorder*.
3. See *Help* for *Sound Recorder* for more information.

USB Device

The computer has an interface called Universal Serial Bus (USB). Its four USB ports support USB1.1 and USB2.0. With a USB connection, you can connect/disconnect peripherals without turning off the computer. Generally, when you connect a device to the computer, the necessary driver will be installed automatically. See also the manuals of peripheral devices supporting USB.

3





The USB ports have different orientations depending on their locations. Before inserting a USB cable, make sure that you are inserting in a correct orientation. (See the illustration below.)

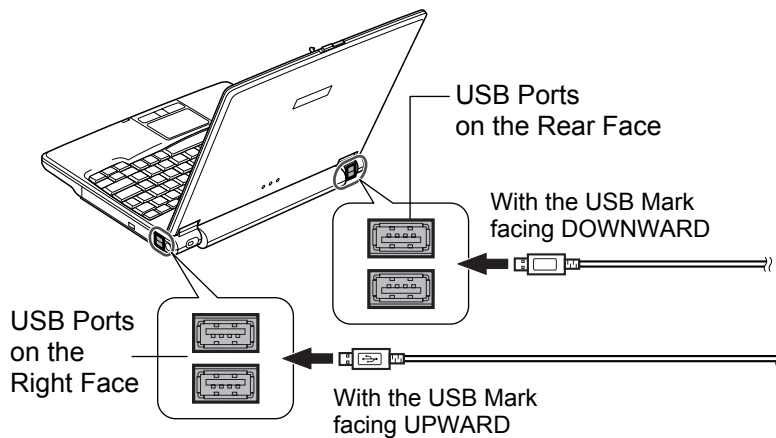

When a new device is correctly connected to the computer, the appropriate driver is automatically installed. If the driver is not correctly installed, you will see the message on the screen. In this case, install the driver following the instructions on the screen.



To remove the USB devices, you may need to perform the following instructions.

1. Click *Safely Remove Hardware* icon () on the taskbar. If you cannot find the icon, click  to show all kinds of icons. If the icon does not appear, go to the step 3.
2. Click *Safely remove xxxx* (xxxx is the name of your USB device); then, the *Safe To Remove Hardware* dialog appears.
3. Remove the device from the computer.

PC Card

The computer is equipped with a PC card (supporting PC Card Standard, CardBus compliant) slot, which can accommodate a Type II card. You can insert/eject the card without turning off the computer. Before inserting a PC card into the slot, refer to its manual.

Inserting PC Card



- *When a new card is correctly inserted, the appropriate driver is automatically installed. If the driver is not installed correctly, you will see the message on the screen. In this case, install the PC card driver by following the instructions on the screen.*
- *When you insert a protruding card such as wireless networking card:*
 - *Do not give force to the card; otherwise the computer may be damaged.*
 - *Do not carry the computer with the card inserted.*

3

1. Confirm the PC card eject button is inside the computer cabinet. If the button is not inside the computer cabinet, push it back into the cabinet.

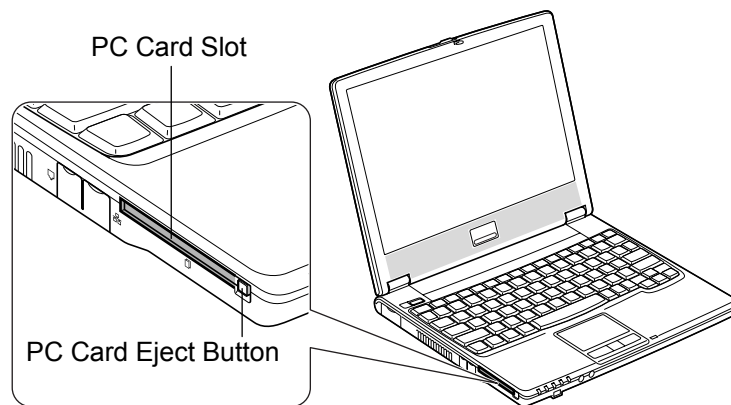

2. Insert a PC card into the slot with the label facing upward until it locks into place.

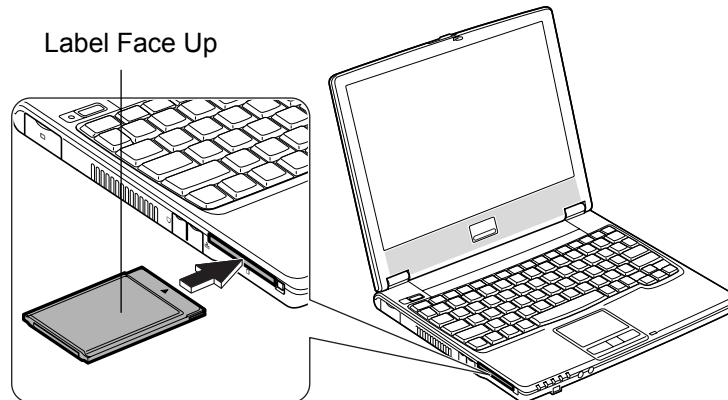



3

If the dialog box asking you *What do you want Windows to do?* appears, select the task you want.

Ejecting PC Card



- *Some PC cards may become hot after long use. Be careful when removing the card from the PC card slot.*
 - *Be sure to use the procedure below when ejecting the PC card. Otherwise, the data on the PC card may be cleared or the system may not work properly.*
-

1. Click *Safely Remove Hardware* icon () on the taskbar. If you cannot find the icon, click  to show all kinds of icons.
2. Click *Safely remove xxxx* (xxxx is the name of your PC card); then, the *Safe To Remove Hardware* dialog appears.

3. Push the PC card eject button so that it will pop out from the side of the computer.

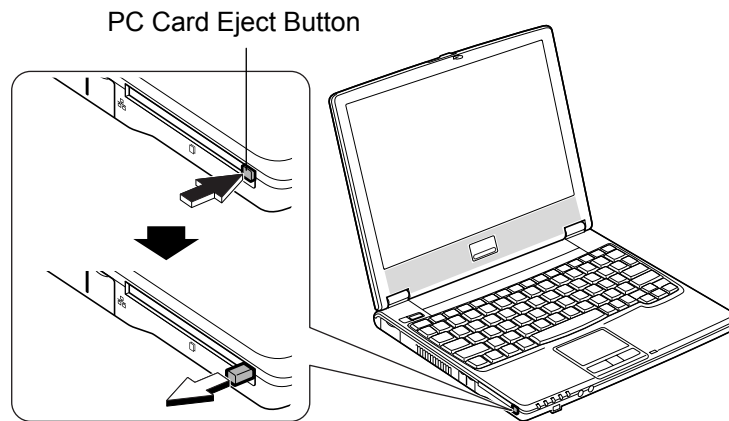

3

4. Push the PC card eject button until the inserted PC card pops out; then, remove it.

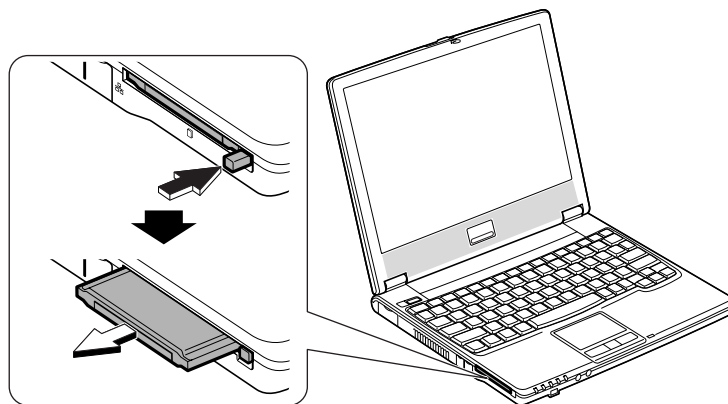

5. Push the PC card eject button all the way inside the cabinet for safekeeping.

Printer

You can connect a USB printer to any of the USB ports on the computer.



Before using a printer, read the printer manual and install the printer driver.

Connecting Printer

3



When connecting the cable to one of the USB ports on the right face of the computer, be sure to let the USB mark (↔) face upward, and when using ones on the rear face, let it downward.



Be sure to read the printer manual before connecting a USB printer to the computer. Some printer may not use the Found New Hardware wizard to install the printer driver.

You can connect the USB printer to the computer without turning off the computer.

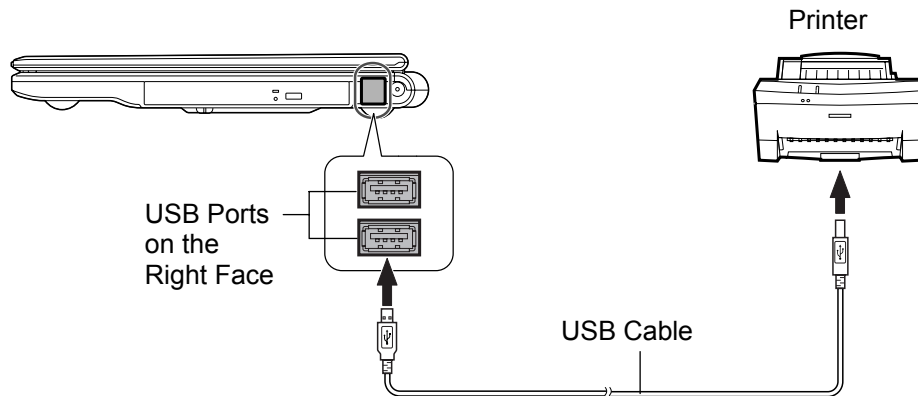

To remove the printer from the computer, refer to the steps in the *USB Device* section.

CHAPTER 4

Communication Functions

This chapter explains how to use the built-in modem, the wired LAN unit, and the wireless LAN function.



- *When you use communication software:*
 - *Connect the computer to the AC power source.*
 - *Disable power management. (Refer to Disabling Power Management of Chapter 2.)*
 - *See also the manual or online help of the software you are using.*
- *The communication speed may vary depending on the traffic, local telecommunications infrastructure, and ISP (Internet Service Provider) infrastructure.*

4

Built-in Modem

You can use the built-in modem for data transfer and fax communication.



- *The built-in modem on the computer is designed only for regular analog telephone lines. The modem may be damaged when connected to a digital ISDN terminal or a digital PBX.*
- *Use TA (terminal adapter) to connect the built-in modem to a digital telephone line.*
- *If an unusual device is attached to the line you are connecting to, the modem may not function properly. Remove the device or contact the dealer of the device.*
- *Before connecting to a PBX, consult the PBX maintenance staff or its service company. If the electric characteristics of your PBX are different from those of a regular analog line, the modem will not function properly. If you connect the modem to a digital PBX, both the modem and the PBX may be damaged.*



- *Within the communications software you are using, set the COM port of the built-in modem to COM 3 and modem name to SmartLink 56K Modem if required.*
- *Before commencing with fax communication, it is recommended that you exit other application programs.*

Connecting Modem to Telephone Line

1. Turn off the computer.
2. Open the cover of the modem jack on the left side of the computer.

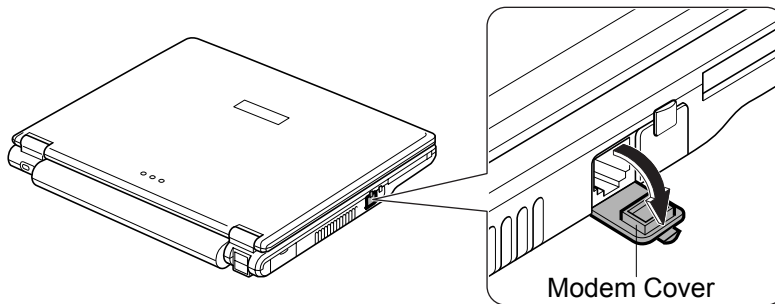

4



To avoid damaging the modem, close the modem cover after you finish using the built-in modem.

3. Connect the core end of the included modem cable to the modem jack and the other end to the telephone line.

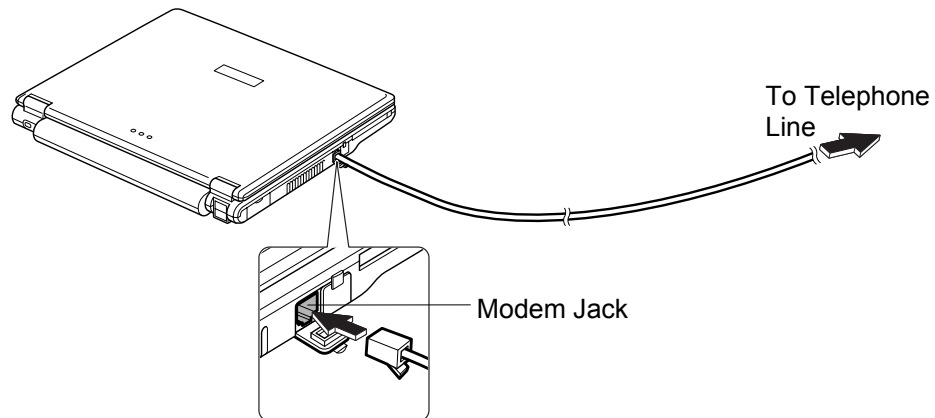

Be sure not to insert the modem cable into the LAN jack. It may damage the LAN jack and the modem cable.



Connect the modem to the telephone line directly. Do not use a distributor or alloter.

4. Turn on the computer.

Configuring Modem

You may have already configured your modem during Windows setup process. Otherwise, make the necessary adjustments as shown below.

Modem Configuration

When you use the modem first time, you must type your location's information.

1. Click *start – Control Panel – Printers and Other Hardware*; then, *Phone and Modem Options*. If the Classic view is selected, double-click the *Phone and Modem Options* icon.
2. In the *Location Information* dialog box, select your country, type your area code, etc. and select your dial type; then, click *OK*.

After the configuration, click or double-click the *Phone and Modem Options* (icon) to open the *Phone and Modem Options* dialog box and double-click the location name in the *Locations* field of the *Dialing Rules* tab for the information you set above. Clicking *Edit...* or *New...* allows you to make a new location or change the settings.

Internet Connection

Windows XP has a special Internet connection wizard to help you to connect to the Internet with ease.



- *If you plan to connect into the Internet and dial an Internet Service Provider (ISP) through the modem, have your account information and dial-up number ready before you begin the wizard.*
- *Once you set your connection, you can see or edit the connection status by double-clicking the icon appearing on the Dial-up field of the Network Connections dialog box.*

1. Click *start – Control Panel - Network and Internet Connections*; then, *Network Connections*. If the Classic view is selected, double-click the *Network Connections* icon.
2. In the *Network Connections* dialog box, click *Create a new connection* of the *Network Tasks* section. The *New Connection Wizard* dialog box appears.
3. Follow the instructions on the screen.

LAN Unit

You can connect to a LAN (Local Area Network) with the 100 Base-TX/10 Base-T LAN units on the computer. To activate the LAN unit, perform the following steps.



Never insert any cables, but a LAN cable, which have different electric characteristics from those of the LAN cable. Otherwise, the LAN unit and the cables may be damaged.



Use a category 3 or a category 5 LAN cable when connecting to 10 BASE-T LAN, and the category 5 only when connecting to 100 BASE-TX LAN.

Connecting Your Computer to LAN

1. Turn off the computer.
2. Open the cover for the LAN jack on the left side of the computer.

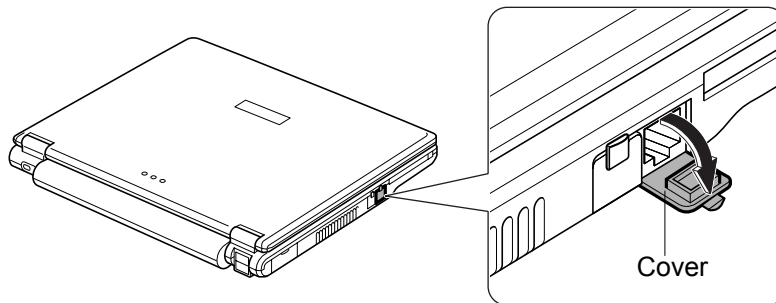

Do not insert the modem cable into the LAN jack. It may damage the modem cable and the LAN jack.



To avoid damaging the LAN unit, close the cover after you finish using the LAN unit.

3. Connect one end of the LAN cable to the LAN jack and the other end to the network hub.

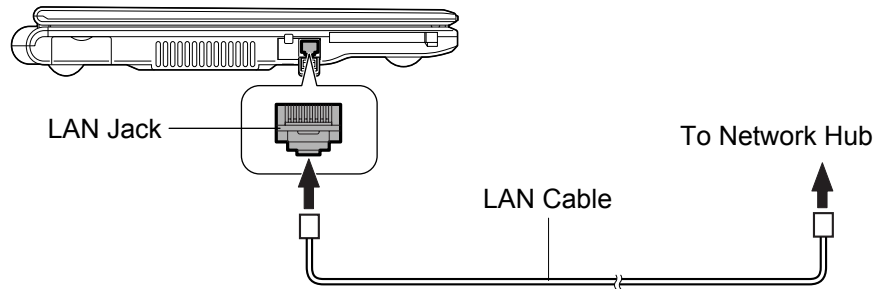

4. Turn on the computer.

Configuring LAN Unit

1. Click *start - Control Panel*.
2. Click *Network and Internet Connections*; then, *Network Connections*. If the Classic view is selected, double-click the *Network Connections* icon.
3. Right-click *Local Area Connection*.
4. From the pop-up menu, click *Properties*.
5. In the *Local Area Connection Properties* dialog box, set the network setting according to the instruction of your network administrator.



Make sure to log on the computer as a member of the Computer administrators group. Otherwise, you cannot set or change some settings for the LAN unit.

If you cannot access the network,

1. Click *start - Control Panel*.
2. Click *Performance and Maintenance*; then, *System*. If Classic view is selected, double-click *System* icon.
3. Click *Hardware* tab; then, the *Device Manager* button.
4. Double-click *Network adapters*, then, *VIA PCI 10/100Mb Fast Ethernet Adapter*.
5. Click the *Advanced* tab, and select *Connection Type* in the *Property* list and select an appropriate value in the *Value* pull-down menu.
6. Click *OK* and close the *Device Manager* window.
7. Click *OK* and close the *Control Panel* window.

Configuring Network Settings

You can configure your network settings in various manners according to network environments. This section provides one of them with the following conditions.

- Two computers, which do not have Internet connections, are connected directly each other with a cross LAN cable.
- The two computers are running on Windows XP.
- The *Network Setup Wizard* is used for network configuration.

Configuring Network Settings of Your Computer



Prior to configuring, be sure to connect two computers with a cross LAN cable.

1. Click *start – All Programs – Accessories – Communications – Network Setup Wizard*. The *Network Setup Wizard* dialog box will open.
2. Click *Next*.
3. Click *Next* again.



When a message “The wizard found disconnected network hardware.” appears:

- *With the Local Area Connection string displayed in the Connections field, click Cancel to quit the wizard and confirm the other computer is powered on or the both computers are connected correctly with a cross cable.*
 - *Otherwise, check the box of Ignore disconnected network hardware and then, click Next.*
4. Select *Other* and click *Next*.
 5. Select the third option, *This computer belongs to a network that does not have an Internet connection*, and click *Next*.
 6. Select the second choice, *Let me choose the connections to my network*, and click *Next*.
 7. Clear all boxes except that of *Local Area Connection*.



Confirm only the box of Local Area Connection is checked.

8. Click *Next*.
9. Input *Computer description* if necessary and *Computer name*, then, click *Next*.



The Computer name should be unique. Type a name that is different from that of the other computer.

10. Type a *Workgroup name* and click *Next*.



The Workgroup name should be same as that of the other computer.

11. Click *Next*. The network configuration will start.
12. Select the forth option, *Just finish the wizard; I don't need to run the wizard on other computers*, and click *Next*.
13. Click *Finish*, then, *Yes*. The computer will restart.

4

Change Your Computer Name or Workgroup Name

When you need to change the computer name or workgroup name, follow these instructions.

1. Click *start – My Computer*.
2. Click *View system information* in *System Tasks* field. The *System Properties* dialog box will open.
3. Click the *Computer Name* tab and the *Change...* button. The *Computer Name Changes* dialog box will appear.
4. Type the *Computer name* and the *Workgroup* in each field and then, click *OK*.
5. Click *OK* twice and *Yes*. The computer will restart.

Sharing Files and Folders

You can share files and folders on each computer when they are permitted to share. With the function you can copy documents stored on your desktop computer to your notebook computer or display data on the computer and the other computer.

Sharing Files and Folders

This section provides how to share a folder on the network. With these steps you can also share a drive.

1. Right-click a folder to be shared and click *Sharing and Security....* The *XXX Properties* dialog box will open. (XXX is the folder's name.)
2. Check the box of *Share this folder on the network*. Confirm the name typed in *Share name* field is the folder name to be shared.



When you have not used Network Setup Wizard or shared any folders or drivers before, follow these instructions to enable file sharing.

1. Click If you understand the security risks but want to share files without running the wizard, click here in *Network Sharing and Security section*. *Enable File Sharing dialog box* will appear.
2. Select *Just enable file sharing and click OK*.
3. Check the box of *Share this folder on the network and type the folder name to be shared in Share name field*.

3. Click *OK*.



A sharing symbol (👉) will be added to the icon of the shared folder.

Copying Shared File

1. Click *start – Control Panel*.
2. Click *Network and Internet Connections*; then, *Network Connections*. If the *Classic view* is selected, double-click the *Network Connections* icon.
3. Click *My Network Places* in the *Other Places* field located on the left.
4. Click *View workgroup computers* in the *Network Tasks* field. All the icons of computers belonging to the same workgroup will appear.
5. Double-click the icon of the other computer. The shared folder(s) will appear.
6. Double-click the shared folder. When a password is required, type it.
7. Drag and drop the desired file to the desktop of the computer. The copied file is created on the computer.
8. Close the window.

Wireless LAN

The computer has an integrated wireless LAN function compliant with IEEE 802.11g standard and IEEE 802.11b standards.



- *The computer can communicate with wireless devices supporting IEEE 802.11g or IEEE 802.11b. Note that there are some devices the computer cannot communicate with even if they support IEEE 802.11g or IEEE 802.11b.*
- *The computer cannot communicate with wireless devices only supporting IEEE 802.11a.*
- *The range to give reliable performance and the quality of connection vary depending on the environment where you perform.*

Wireless LAN Modes

There are two kinds of wireless LAN modes: Infrastructure mode and Ad Hoc mode.

Access Point (Infrastructure) Mode

Infrastructure mode refers to a wireless network in which wireless devices communicate with each other through an access point (AP). Wireless devices can communicate with each other or can communicate with a wired network through AP.

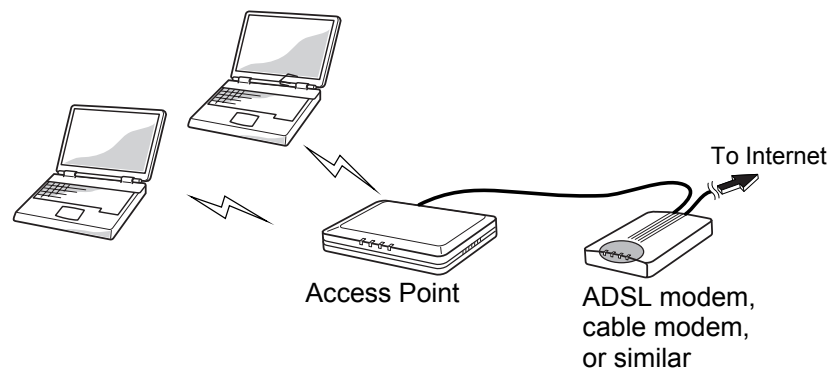

Ad Hoc Mode

Ad Hoc mode refers to a type of network that consists of multiple computers each equipped with a wireless networking interface. Each computer can communicate directly with other wireless enabled computer.

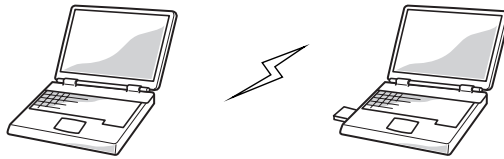

The data is transmitted according to the IEEE 802.11b in ad-hoc mode.

4

Security Measures

Since wireless LAN provides data transfer using electric waves instead of LAN cables between communicating devices, a third party can illegally access to and monitor the transmitted information. The following security measures reduce opportunities to receive the threats. Use a combination of the following measures for more secure communications.



See the Notice of Security with Wireless Devices section on page xv.

Authentication

The following may help you to protect your important data from illegal access.

- **SSID (Service Set Identifier)**

“SSID” is a common network name. An SSID acts as a password that is shared with all connecting wireless devices, resulting in preventing access by any device that does not have the SSID. Set a same SSID on the computer and an access point which you are using. To enhance the security, rely on a combination of the SSID and WEP or WPA security. (For details on configuration of the access point, refer to its manual.)

• **MAC (Media Access Control) address filtering**

MAC addresses are unique addresses on the network, which are assigned to the computer's network interface cards. An access point allows access by only devices if their MAC addresses match the addresses in an authentication list used by the access point. Register your MAC address with the access point which you are using. (For more information, refer to the manual of the access point.)



To confirm the MAC address of the computer;

1. Click start – All Programs – Accessories – Command Prompt.
2. Type ipconfig/all and press **Enter**.
3. Confirm the numbers of Physical Address in the Ethernet adapter Wireless Network Connection field.
4. Type exit and press **Enter**.

• **WPA (Wi-Fi Protected Access)**

The computer supports WPA, a wireless LAN security standard increasing the level of data protection and access control compared to WEP (Wired Equivalent Privacy) encryption. To use the WPA security, a WPA-enabled access point is required. To implement user authentication, one of the security enhancements of WPA, an authentication server is needed. For details on WPA features, consult your network administrator or the manual of the access point which you are using.

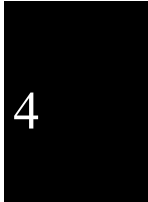

Encryption

The computer provides new encryption mechanisms, TKIP and AES, as well as the WEP. All of the TKIP, AES and WEP techniques can transmit encrypted data to make illegal interception more difficult.



- *To use the WEP functions, your communication partner must support the functions.*
- *To utilize TKIP, the access point which you are using must support TKIP.*
- *To utilize AES, the access point which you are using must support AES.*

• **WEP (Wired Equivalent Privacy)**

WEP relies on an encryption key that is shared between a wireless device and an access point. The key is used to encrypt data and decrypt the transmitted data.



- The computer supports 128-bit and 64-bit WEP keys.
- For enhancement of security, the encryption keys should be periodically changed.

- **TKIP (Temporal Key Integrity Protocol)**



TKIP provides an improved data encryption, which was weak in WEP. The TKIP encryption automatically generates a new unique encryption key periodically for each device to avoid the same key staying in use for weeks as they do with WEP.

- **AES (Advanced Encryption Standard)**

AES is a stronger form of encryption than is found in the WPA protocol and is the security standard approved by US Government organizations.

4

Activating Antenna

To communicate through wireless LAN, the integrated antennas must be activated. You can enable/disable the antennas by pressing the **Fn+F1** () key combination. When the antenna indicator () lights green, the antennas are enabled. When the indicator light is off, they are disabled.

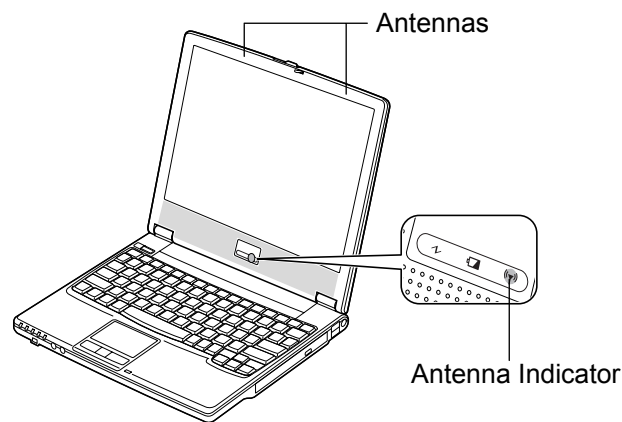

Disable the antennas on airplanes and in specific place where radio-susceptible equipment is nearby such as medical electrical equipment. Electric waves generated from the antennas may affect the devices and cause malfunction of the devices.

Connecting to Network via an Access Point

You can connect the computer to the Internet or a wired network via an access point supporting IEEE 802.11g or IEEE 802.11b. For details on the access point, refer to its manual or consult your network administrator.





This section describes how to communicate or access to the Internet through the access point.

Configuring Wireless LAN Setting

The following steps lead you to configure the wireless LAN setting by automatically obtaining the IP address, DNS server, etc. from an access point. By default, no configuration is needed. Skip these steps and go to the *Connecting to Network* section on the next page.



- *There are some access points requiring the specific IP address, subnet mask, default gateway and DNS server on the computer. Refer to the manual of the access point or consult your network administrator.*
- *You can store the configured settings using Network Setup Utility, which allows you to easily access to one of the stored networks appropriate to the current environment. (For the Network Setup Utility, refer to the Network Setup Utility section later in this chapter.)*

1. Right-click the *Wireless Network Connection* icon (,  or ) on the taskbar. If you cannot find the icon click  to show all kinds of icons.
2. Click *Change advanced settings* of the *Related Tasks* field.
3. Double-click *Internet Protocol (TCP/IP)* in *This connection uses the following items*.
4. Confirm the radio buttons of *Obtain an IP address automatically* and *Obtain DNS server address automatically* are selected. If not, select them.



This step will remove the existing IP address, subnet mask, default gateway and DNS server if they have been already assigned. Write down the information before you perform this step.

5. Click the *Advanced* button.
6. Confirm the *Default gateways* section is emptied. If not, remove the gateway address.
7. Click *OK* each time you close the dialog boxes.
8. Close the *Network Connections* window.



Connecting to Network

This section describes how to connect to a WEP enabled access point or WPA-PSK/TKIP capable access point. (WPA-PSK/TKIP refers to WPA with pre-shared key (PSK) with Temporal Key Integrity Protocol (TKIP) encryption.) For access points with user authentication, consult your network administrator.



WPA-PSK is a special mode allowing only devices with a matching network key to access the WPA-PSK capable access point.

Before connecting to wireless network, confirm the access point that you are using is powered on and ready to use. (Refer to its manual.)

1. Confirm the antenna indicator is lit.
2. Right-click the *Wireless Network Connection* icon () on the taskbar. If you cannot find the icon click  to show all kinds of icons.
3. Click *View Available Wireless Networks*.
4. Select a network to be connected from the list and then, click *Connect*.
5. Type the correct network key in the fields of *Network key* and *Confirm network key*.

Network keys are generated from ASCII or hexadecimal entries. Refer to the following table for available letters and digits.

	WEP Access Point	WPA-PSK/TKIP or AES Access Point
ASCII format ^{*1}	5 or 13 characters	8 to 63 characters
Hexadecimal format ^{*2}	10 or 26 digits	64 digits

^{*1} 0 to 9, a to z, and A to Z (The uppercase and lowercase letters are distinguished.)

^{*2} 0 to 9, a to f, and A to F (The uppercase and lowercase letters are not distinguished.)



*When you select a network that is not configured for encryption settings, the caution message appears. Read the message carefully. Although you can connect to the network by clicking *Connect Anyway*, security is not ensured. Select a security configured network.*

6. Click *Connect*.



- When the computer successfully connects to the selected access point, the Connected signage will appear in the connected network name field and the Wireless Network Connection icon (📶) on the taskbar will change to (📶).
- Entering an incorrect network key or selecting an inappropriate key index will show the Limited or no connectivity signage in the network name field and the icon on the taskbar will change to (📶). Reenter the correct network key and/or change the key index referring to the Changing Security Mode section on page 4-18.
- To establish a new connection to another access point, firstly disconnect the current connection and then, perform the steps 3 and 4. (To disconnect the current connection, select the connected access point in the Wireless Network Connection dialog box and then, click Disconnect.)

Confirming Status of Wireless Connection

The *Wireless Network Connection* icon on the taskbar shows the current wireless connection status.

Icon	Connection status
	Disconnected
	Trying to connect
	Being connected
	Failed to connect

To check the connection speed and quality:

1. Click the *Wireless Network Connection* icon (📶) on the taskbar. If you cannot find the icon, click ⚙️ to show all kinds of icon.
2. In the *Wireless Network Connection Status* dialog box, confirm your connection status.



- The number of the green signals (📶) shows the connection quality. The more signals light on, the better quality is given to the computer.
- When the quality of connection is poor, adjust the distance between the computer and other devices or the access point you are communicating with and/or the facing direction of the computer.

3. Click *Close*.

Communicating with Other Computers

This section describes how to communicate between wireless computers with a built-in wireless module or a wireless LAN card installed.





To enable wireless communication between the computers;

- Assign IP address and subnet mask for each computer.
- Set the communication mode to ad hoc.
- Give the same network name (SSID) to each computer.
- Set the encryption key (WEP key)



TKIP and AES cannot be utilized in ad-hoc mode.

4

1. Right-click the *Wireless Network Connection* icon (,  or ) on the taskbar. If you cannot find the icon click  to show all kinds of icons.
2. Click *Change advanced settings* of the *Related Tasks* field.
3. Select *Wireless Network Connection*; then, click *Change settings of this connection* of *Network Tasks*.
4. Double-click *Internet Protocol (TCP/IP)* in *This connection uses the following items*.
5. In the *Internet Protocol (TCP/IP) Properties* dialog box, select *Use the following IP address* and set the *IP address* to 192.168.1.2 through 192.168.1.254 and the *Subnet mask* to 255.255.255.0; then, click *OK*.



- *The IP address of each computer should be unique.*
- *The same subnet mask should be set to all computers.*
- *The Default gateway can be blank.*

6. Click the *Wireless Networks* tab; then, the *Advanced* button in the lower right of the dialog box. The *Advanced* dialog box appears.
7. Select *Computer-to-computer (ad hoc) networks only*; then, click the *Close* button.
8. Click the *Add...* button in *Preferred networks* of the *Wireless Network Connection Properties* dialog box.

9. Type a name of the network in *Network name (SSID)* field of *Wireless Network Properties* dialog box.



Confirm the computer and other computers are assigned the same Network name.

10. Confirm *Open* is selected in the *Network Authentication* pull-down menu and *WEP* in the *Data encryption* pull-down menu.
11. Clear the checkbox of *The key is provided for me automatically*.
12. Type the same network key as that of the partner in the *Network key* and *Confirm network key* fields.

Network keys are generated from ASCII or hexadecimal entries. Refer to the following table for available letters and digits.

ASCII format ^{*1}	5 or 13 characters
Hexadecimal format ^{*2}	10 or 26 digits

^{*1} 0 to 9, a to z, and A to Z (The uppercase and lowercase letters are distinguished.)

^{*2} 0 to 9, a to f, and A to F (The uppercase and lowercase letters are not distinguished.)



- *The network key to be typed must be equal to that of the partner(s).*
- *Be sure to match the key index between the computer and the other computer(s). Note some computers have the key index options 0 through 3. Refer to the Key index matching table on page 4-21.*

13. Click *OK* twice; then, close the *Control Panel* window.
14. Configure the network by setting the name of the computer and workgroup.



To communicate with other wireless enabled computers, set the computer name and the workgroup name. The computer name should be unique and the workgroup name should be same as others. (Refer to the Changing Your Computer Name or Workgroup Name section on page 4-7.)

To share the folder(s) on the computer with other computers, refer to the Sharing File and Folders section on page 4-8.





Changing Security Mode

This section describes how to change the security mode to WEP or WPA-PSK with TKIP or AES.



When using the user authentication security technology, consult your network administrator for the mode changes.

WEP

1. Right-click the *Wireless Network Connection* icon (, , or ) on the taskbar.
2. Select *View Available Wireless Networks*.
3. In the *Related Tasks* field, click *Change the order of preferred networks*.



The Wireless Network Connection Properties dialog box will appear.

4. In the *Preferred networks* field, select the network to be given the security change and then, click *Properties*.
5. Select *Open* in the *Network Authentication* pull-down menu and *WEP* in the *Data encryption* pull-down menu.
6. Clear the box of the *The key is provided for me automatically*.
7. Type the same network key as the other device to be communicated with in the *Network key* and *Confirm network key* fields.



Available letters and digits are following;

ASCII format ^{*1}	5 or 13 characters
Hexadecimal format ^{*2}	10 or 26 digits

^{*1} 0 to 9, a to z, and A to Z (The uppercase and lowercase letters are distinguished.)

^{*2} 0 to 9, a to f, and A to F (The uppercase and lowercase letters are not distinguished.)

8. If necessary, change the key index in the *key index* fields.



- The key index options of the computer are 1 through 4.
- Some access points and computers have the options 0 through 3. Refer to the table below for matching.

Key index matching table

Access Point1 /Computer1	Access Point2 /Computer2	Your computer
1	0	1
2	1	2
3	2	3
4	3	4

(ex. When your access point type is "Access Point 2" and its key index is set to 0, set 1 to the key index of your computer.)

9. Click *OK* twice and close the *Wireless Network Connection Properties* dialog box.

4

WPA-PSK with TKIP or AES

1. Follow the steps 1 to 4 in the *WEP* section above.
2. Select *WPA-PSK* in the *Network Authentication* pull-down menu and *TKIP* or *AES* in the *Data encryption* pull-down menu.
3. Type the same network key as the other device to be communicated with in the *Network key* and *Confirm network key* fields.



Available letters and digits are following;

ASCII format ^{*1}	8 through 63 characters
Hexadecimal format ^{*2}	64 digits

^{*1} 0 to 9, a to z, and A to Z (The uppercase and lowercase letters are distinguished.)

^{*2} 0 to 9, a to f, and A to F (The uppercase and lowercase letters are not distinguished.)

4. Click *OK* twice and close the *Wireless Network Connection Properties* dialog box.

Network Setup Utility

With the Network Setup Utility, you can define specific network settings based on your network environments such as work, home, etc. You can also allow for the computer automatically to switch to the appropriate network.



- *Not every setting item can be stored.*
- *The Network Setup Utility may not be compliant with all network environments.*
- *The Help of the Network Setup Utility will give you more information.*

Running Network Setup Utility

For the first use;

1. Click *start – All Programs – Network Setup Utility – Network Setup Utility*.



The Network Setup Utility icon (⚙️) will appear on the taskbar.

2. Click the *Network Setup Utility* icon (⚙️) on the taskbar.
3. Read the message and then, click *Yes* or *No*.

For the second use and later;

- When *Yes* is chosen in the step 3 above, the *Network Setup Utility* will automatically run on Windows start-up.
- When *No* is chosen in the step 3 above, click *start – All Programs - Network Setup Utility –Network Setup Utility*.

Loading Network Settings

To set your specific network setting, confirm that the computer is connected into the network and has the proper settings for your current environment and follow the instructions below.

1. Confirm the current network setting is to be loaded.
2. Run the *Network Setup Utility* to display the *Network Setup Utility* window.
3. Click the (⚙️) icon.
4. Click *OK* in the confirmation window.

5. In the *Register an icon and network name* dialog box, select the *SHARP icon* or *Windows icon*, then, click the *Select icon* button.
6. Select an icon and click *OK*.
7. Type a network name, then, click *OK*. The selected icon appears on the main screen of the *Network Setup Utility* window.



It takes a moment to load and register the network settings.

Using or Switching to Network

Using or Switching to Loaded Network

To use or switch the loaded network, confirm the computer is ready to connect into the network and follow these steps.

1. Run the *Network Setup Utility* to display the *Network Setup Utility* window.
2. Select the appropriate network icon in the *Network Setup Utility* window.
3. Click *OK*.



- *Make sure the computer is connected to the proper environment.*
- *If your hardware or software configuration has been changed, you may not be able to switch to the network properly. In this case, you may need to reconfigure the network settings.*

Automatically Switching to Available Network

The computer supports the auto-switching function, “Auto Pilot,” automatically to detect one of the available networks registered and switch to it.

1. Run the *Network Setup Utility* to display the *Network Setup Utility* window.
2. Click the *Auto Pilot* icon (⚙️).
3. Read the message in the confirmation window and click *OK*.



- *It will take a moment to switch to the auto pilot mode.*
- *To exit from the auto pilot mode, click the icon (⚙️) again.*

4

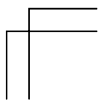
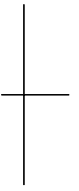
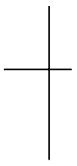
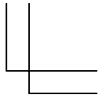
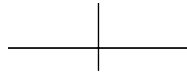
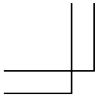

CHAPTER 5

Setup Utility

This chapter describes how to run the Setup Utility to change settings on the computer.

Running Setup Utility

With the Setup Utility, you can customize the system configuration information, such as time and date, port assignments, or passwords. The information you have specified is saved in a special area called CMOS RAM, which the system reads every time you turn on the computer. The computer is shipped from the factory with the appropriate setting of the Setup Utility. Leave it as default in normal use.

5

Contents of Setup Utility

The Setup Utility consists of four menu pages, as follows:

- Main: Configures basic setting
- Advanced: Configures device interface
- Security: Sets Passwords
- Exit: Exits the Setup Utility or returns to the default values

Entering and Exiting Setup Utility

1. Turn on the computer.
2. When *<F2> to enter System Configuration Utility* appears, press **F2**.
3. Change to the desired settings. Refer to the next section.
4. Select *Exit* menu; then, press **Enter**.
5. Select one of the exit methods, and press **Enter**.
6. Confirm the message and press **Enter** again. The system restarts.







When the Setup Utility is opened, power management does not work. Do not close the display cover.

Changing Setting of Setup Utility

To change the settings:

1. Use → or ← key to select the menu.
2. Use ↑ or ↓ key to select the item.

If the item has  or :

Press **Enter** to enable or disable the item.  mark means the item is enabled.  mark means disabled.

If the item has no mark (except *Date and Time* of *Main* menu and *Set Password* of *Security* menu):

1. Press **Enter** to open the sub menu.
2. Use **Tab** key to highlight the value; then use ↑ or ↓ key to select the value. The value with  is being selected.
3. Use **Tab** key to highlight *OK*; then press **Enter**.

To set *Date and Time*:

1. Press **Enter**.
2. Use arrow keys to highlight the value; then use minus key or space bar to change the value.
3. Use arrow keys to highlight *OK*; then press **Enter**.

Minus or **Space** key : Changes the value.

3. Close the Setup Utility according to the steps above.



Main Menu

Date and Time defines the system date and time, using the format *month/day/year* and *hour:minute:second* (24-hour format). Use **Tab** key to move the cursor, and minus key or space bar to change numerals.

Hard Disk Type defines the type of the hard disk of the computer. Normally use as default (Ultra DMA-100).

Boot Sequence specifies where the system boots from. Press **Enter** to open the sub menu. The system boots from the drive selected in *1st Boot Device*. If the system cannot find the drive, it will boot from the drive selected in *2nd Boot Device*; then, the drive selected in *3rd Boot Device*.

Internal NumLock defines whether the numlock keys of the built-in keyboard are always disabled or not. (Num lock indicator will turn when **Fn+NumLk** are pressed regardless of this setting. An external keyboard will be numlocked if connected.)

Hot Key Beep defines whether the beep sounds when **Fn+F1**, **Fn+F5-F8**, **F11-F12** keys simultaneously pressed.

USB Emulation defines whether USB devices (a keyboard, a mouse or an optional external floppy disk drive) can be used in DOS mode. (When it is set to *Disabled*, you cannot boot the computer from a floppy disk.)

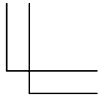
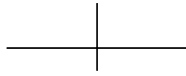

Advanced Menu

Internal Pointing Device enables or disables the built-in touchpad.

Shared Video Memory defines the size for the video memory that will be shared with the extend memory. The available sizes are 8MB, 16MB, and 32MB)

Resolution Expansion defines whether the Setup Utility screen is expanded when the resolution is 640x480 or 800x600. When this item has  mark, the screen is expanded (this item does not work in the Windows environment).

Battery Low Warning Beep enables or disables the beep sound when the battery remaining capacity becomes extremely low (this item does not work for Windows battery alarm).

LAN Boot defines whether the system boots from the PXE server when the integrated LAN is activated.

Wake on LAN defines whether the system resumes from System Standby when the LAN unit of the computer becomes active.

Wake on Ring defines whether the system resumes from System Standby when the built-in modem receives a call.

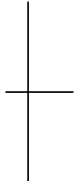

Security Menu

Set Password defines the password (up to eight characters). See the next section about the password.



If you lose your password, you will be unable to access the computer or change the configuration. Make sure to select a password you will never forget, or write it down and protect it in a secure place. Otherwise, you will have to contact your dealer for assistance.

Hard Disk Virus Protect defines whether the boot sector of the hard disk is write-protected. When formatting the hard disk or reinstalling software, set to “_”.

Password

Setting a password will protect the computer against unauthorized access. Once a password is set, the system requires the password when entering to the Setup Utility.

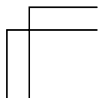



If you enter a wrong password three times, the message “System will be shut down” appears. Press **Enter** to shut down the computer, and after 10 seconds, press the power button to turn it on again.

If *Password on Boot* is enabled, the system will require a password when the computer is turned on.

Setting Password

1. In the *Security* menu of the Setup Utility, select *Set Password* and press **Enter**.
2. Type your password (up to eight characters), and press **Enter**.
3. Type the same password again, and press **Enter** twice.
4. Select *Exit* menu and confirm *Exit Saving Changes* is highlighted; then press **Enter**.
5. Confirm *OK* is highlighted and press **Enter**. The system restarts.

Changing Password

1. In the *Security* menu of the Setup Utility, select *Set Password* and press **Enter**.
2. Type your current password, and press **Enter**.
3. Type your new password, and press **Enter**.
4. Type your new password again, and press **Enter** twice.
5. Select *Exit* menu and confirm *Exit Saving Changes* is highlighted; then press **Enter**.
6. Confirm *OK* is highlighted and press **Enter**. The system restarts.

Deleting Password

1. In the *Security* menu of the Setup Utility, select *Set Password* and press **Enter**.
2. Type your current password, and press **Enter**.
3. Without typing any characters, press **Enter**.
4. Press **Enter** twice.
5. Select *Exit* menu and confirm *Exit Saving Changes* is highlighted; then press **Enter**.
6. Confirm *OK* is highlighted and press **Enter**. The system restarts.



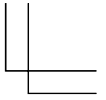
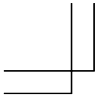

Exit Menu

Exit Saving Changes saves the settings you have changed and exits the Setup Utility.

Exit Discarding Changes exits the Setup Utility without saving the settings you have changed.

Load Setup Defaults returns the values of all items to the default. To exit, select one of the above items.

Discard Changes returns the values of all items to the values you last saved. To exit, select one of the above two items.

Save Changes saves the settings you have changed. To exit, select one of the above two items.

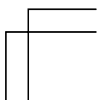
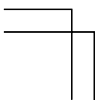
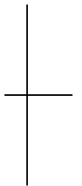

Appendixes

The appendixes contain additional information on the use and care of the computer.

Memory Module

You can upgrade the memory size of the computer up to 768MB by changing the installed memory module. For available memory modules, contact your local dealer.

Changing Memory Module



- *Do not handle the memory module in the location where static electricity is easily generated such as on the carpet.*
 - *Before changing the memory module, carefully discharge static electricity from your body by touching an unpainted metal area.*
 - *Avoid touching the integrated circuits on a memory module. Handle all components by the edges.*
 - *Keep a new memory module in the anti-static wrapping until you are ready to install it.*
-

1. Turn off the computer, and disconnect the AC adapter and remove the battery pack and peripheral devices. See Chapter 2 for removing the battery.
-



- *Make sure to turn off the computer and remove the AC adapter. Otherwise you may get an electrical shock.*
 - *After a long use of the computer, the temperature inside the computer may be hot. Leave it alone for a minimum of one hour before going to the next step.*
-

2. Close the display cover and turn the computer over on a stable surface.

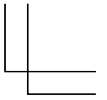
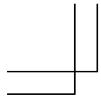

- Loosen two screws and remove the memory slot cover.

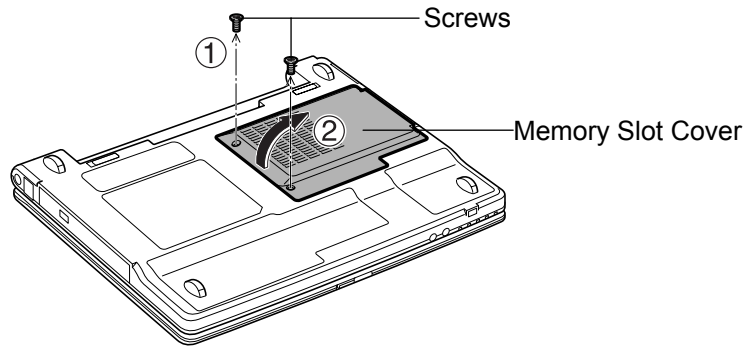

- Remove the installed memory module. (Refer to the *Uninstalling Memory Module* section on page A-4.)
- Align a new memory module as shown below, matching the notched part of the module with the projecting part of the memory socket of the computer.



The cooling fan may be hot. Be careful not to touch it while installing the memory module.

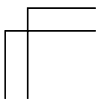
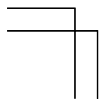
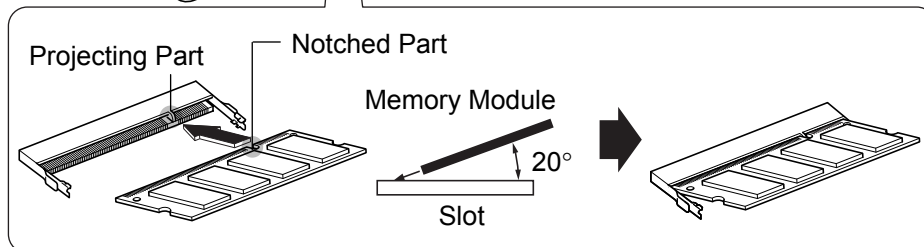
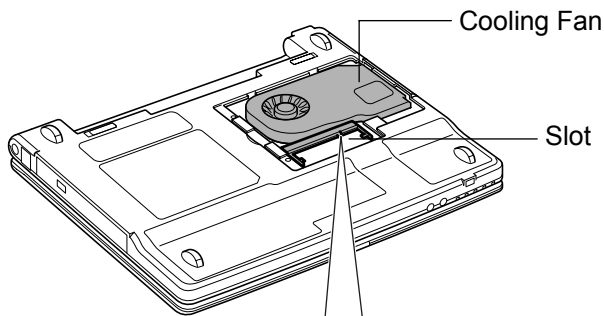

6. Press the memory module slowly to place it into the memory socket, matching the notched parts of the module with the projecting parts of the socket, until you hear the clicking sound.

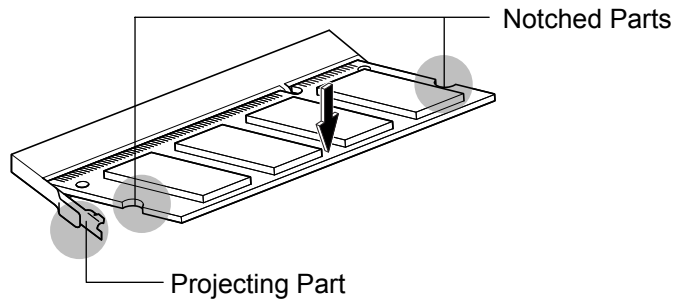

7. Replace the memory slot cover, matching the projecting parts of the cover with the notched parts of the computer.

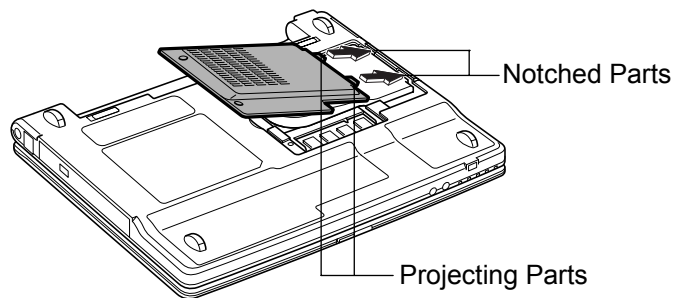

8. Tighten the screws.

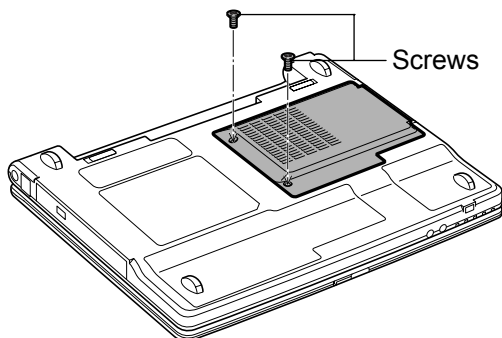

9. Install the battery pack, turn over the computer and connect the AC adapter.



See Chapter 2 for installing the battery pack.

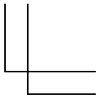
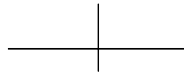
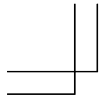

10. Open the display cover; turn on the computer and check the memory size; by clicking *start – My Computer – View system information* of *System Tasks*. Your memory size appears at the bottom of the sentence in *General* tab. Shared video memory size will not be included with the value.

Uninstalling Memory Module

1. Follow steps 1-3 of the *Changing Memory Module* section.
2. Slightly bend both latches outwards until the memory module is released.

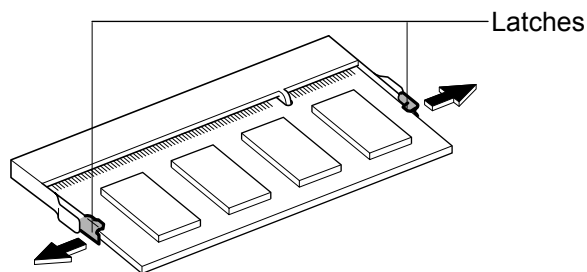

3. Remove the memory module and follow steps 7-10 of the *Changing Memory Module* section.

Maintenance and Care

This appendix provides you with information on how to maintain the computer in excellent working condition.

Replacing Backup Battery

The computer is equipped a backup battery for keeping the information of the Setup Utility, etc. If you see the message *Press <F1> to Continue, Del to Load CMOS defaults*, replace it with a new one. Contact the *Customer Assistance* for a new backup battery (see page iv).

1. Turn off the computer, disconnect the AC adapter, and remove the battery pack from the computer.



Make sure to turn off the computer and remove the AC adapter and the battery pack from the computer. Otherwise the computer may malfunction.

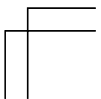
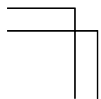

2. Loosen the screws and remove the cover of the backup battery box.

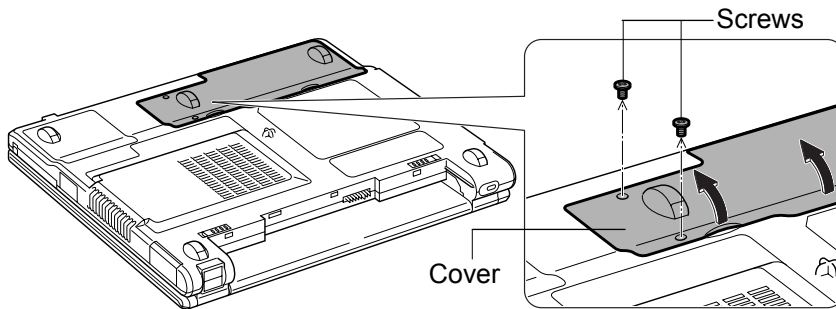

3. Remove the tape securing the cables and pull out the cables connecting the backup battery with the computer.

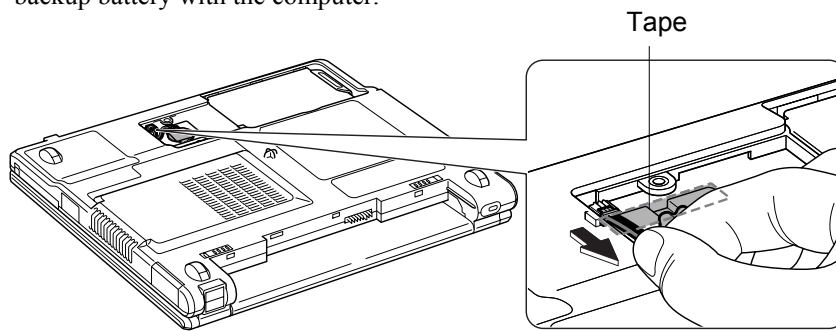

Pinch the cables as close to the connector as possible.

4. Slowly remove the backup battery while lightly holding the sponge.

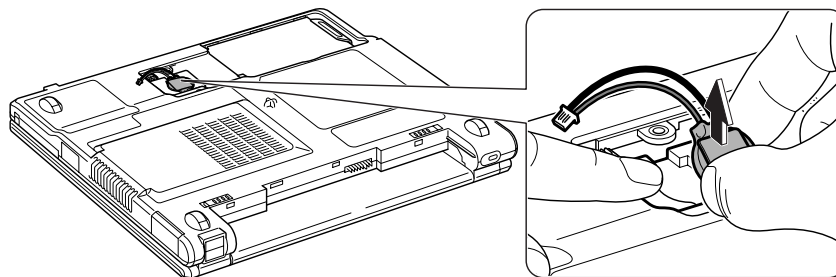

5. Plug the connector of a new backup battery to the computer with the notched part facing upward. Make sure the black cable comes right and the red cable comes left.

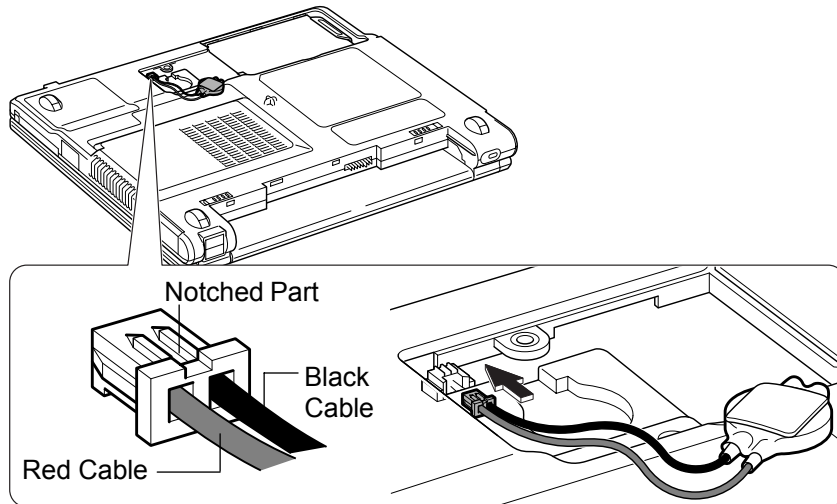

6. Insert the new backup battery to the computer with its tape side down into the pattern on the sponge and properly attach it with the adhesive tape.
7. Secure the cables with the tape again and replace the cover on the computer matching the projected parts of the cover with the notched parts of the computer.

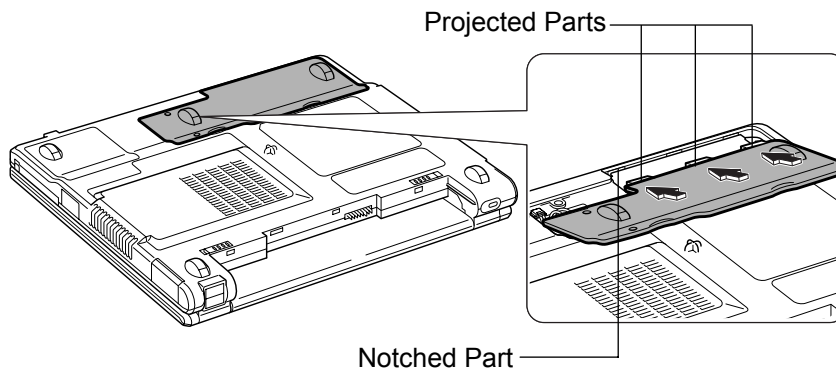

8. Tighten the screws.

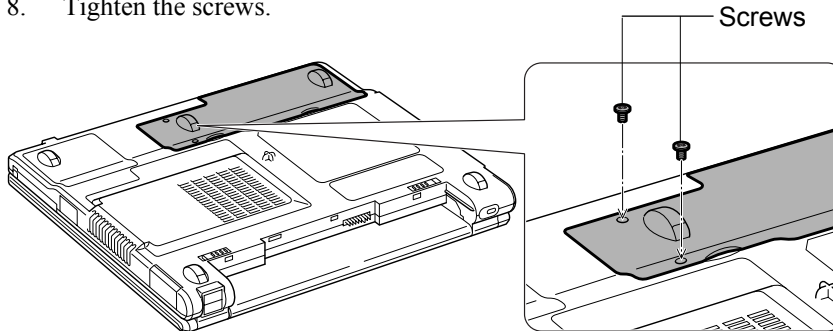

9. Insert the battery pack.
10. Turn the computer over and connect the AC adapter.
11. Turn on the computer.
12. If you see the message *Press F1 to Continue, Del to Load CMOS defaults*. It may take approximately one minute for this message to appear.
13. Press the **Delete** key, and Windows starts up.
14. Click *start – Control Panel*.
15. Click *Date, Time, Language, and Regional Options* in Category view; then, click on *Change the date and time* string.
16. Set date and time; then, click OK.
17. Close the *Control Panel* window.

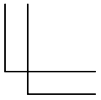
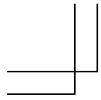

Using Security Cable

You can connect a commercial security cable to the security slot on the computer to prevent theft.

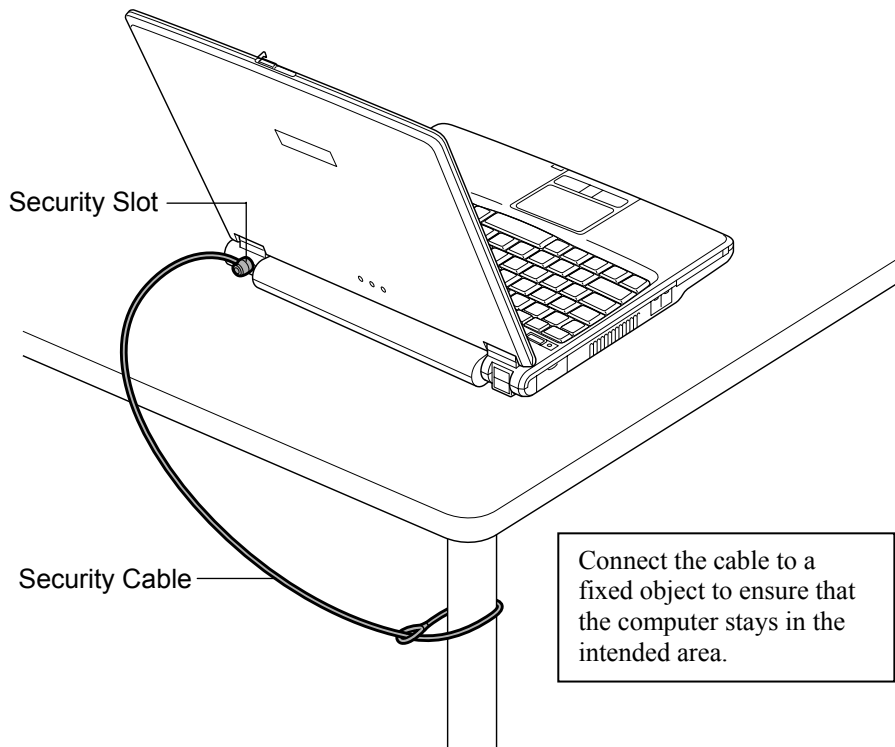

Cleaning Computer

Cabinet

Apply a small amount of mild cleaning solution to a dry, lint-free cloth and wipe the cabinet with the cloth.



- *Never clean the computer while it is powered on.*
 - *Do not use alcohol, benzene, thinner or other strong chemical agents that may damage the cabinet.*
-

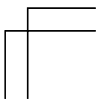
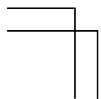



Screen

The surface of the screen may become smeared and accumulate dust during use. Avoid touching the screen with your fingers when using the system. Gently wipe the surface of the screen with a soft cloth that has been dipped in a mild detergent solution and squeezed dry.

Touchpad

Wipe the touchpad with a soft, dry cloth.

Ventilation Openings

Dust on the ventilation openings may cause overheating of the computer. Wipe the ventilation openings with a soft, dry cloth.

Traveling with Your Computer

The computer is designed for portability. For safety and convenience when traveling, please follow these guidelines.

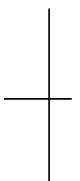
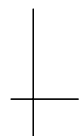
- 
- Before traveling, back up your data on external media.
 - Do not travel with a protruding PC card inserted in the PC card slot of the computer.
 - Do not carry the computer powered on. This may result in loss of data and/or damage to the hard disk drive.
 - Make sure the display cover is completely closed before traveling. Otherwise the cover may be opened unexpectedly, and the display and/or the keyboard will be damaged.
 - If you carry the computer in a bag, try to avoid unnecessary pressure, caused by the stuff of the bag, to the computer.
 - Disconnect the AC adapter and any other cables and any peripherals from the computer.
 - Fully charge the battery pack, and bring the AC adapter and the AC power cord with the computer.
 - Avoid sudden shocks or extreme vibration.
- 

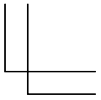
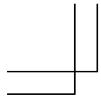

Virus Protection

Computer viruses are programs written intentionally to enter a computer without the user's permission or knowledge. When the computer is infected, several types of damage may occur; data in the hard disk may be destroyed; the computer may be provided external operation by unauthorized users; you may inadvertently attach infected files to your e-mails resulting in spreading the viruses, for example.

To help prevent virus infection, the following measures are encouraged:

- Install the latest virus protection/cleaner software into the computer.
- Apply the latest virus definition file for prevention of new virus attack.
- Before opening incoming files such as attached files, downloaded files, etc, detect the virus infecting them.
- Do not open e-mails originated from unknown place.
- Enables the security functions of application to be used.
(i.e. Disable the macros when handling word or excel files.)
- Regularly update Windows or the applications/software on the computer.
- Back up your important data regularly.

When virus infections occur

Eliminate the virus by means of the latest anti-virus software or virus cleaner software. When it fails, recover all the hard disks. (For recovering the hard disks, refer to the *Re-installation Instructions* section on page A-14.)

Updating Windows



Enabling Automatic Updates

If the Automatic Updates is turned off on the computer, follow these steps.

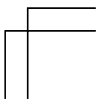
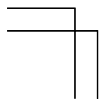

- *You can check the current Automatic Updates status by following these steps. If it is turned off, turn it on.*
 1. *Click start – Control Panel – Security Center.*
 2. *See the Automatic Updates field in the Security Center window. If the Automatic Updates is ON, the function is enabled.*
- *When the Automatic Updates is turned on, the computer will automatically detect the important programs to be updated and install them if any.*



- 
- 
- 
1. Click *start – Control Panel – Security Center*.
 2. In the Security Center window, click the *Turn on Automatic Updates* button.
 3. Close the window.

Updating Windows

You can update Windows by clicking the Windows Update icon on the taskbar or accessing to the Microsoft site.

For more information, visit the *Windows Help and Support Center*.

Protecting Your Computer against Virus

The *Norton AntiVirus* software is preinstalled on the computer for detecting and eliminating viruses. Since the software downloads the latest information or data through the Internet, the computer needs to be connected to the Internet. Some of the software features are below:

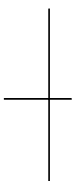
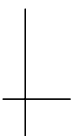
- 
- 
- Regularly updates itself to maintain the latest program and virus definition file against new virus threats. (LiveUpdate)
 - Automatically scans all incoming messages and attachments so that viruses can be identified and blocked. Also detects viruses intruded into the computer. (Auto-Protect)
 - Manually detects infected programs or files. (Virus Scan)
Refer to *Help* of the *Norton AntiVirus* for more information.



- *By default, the Norton AntiVirus software:*
 - *Enables the Auto Protect function.*
 - *Scans the computer for virus weekly.*
- *Refer to the Help and Support of the Norton AntiVirus software for details.*

Enabling Norton Antivirus Software

To use the preinstalled Norton Antivirus software for the first time, you must complete the Norton Antivirus wizard to enable it and update the definition file.

1. Connect the computer to the Internet.
2. Click *start – All Programs – Norton AntiVirus – Norton Antivirus 2004*.
3. Follow the on-screen instructions to complete the *Norton Antivirus* wizard and the *LiveUpdate*.

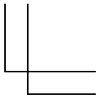
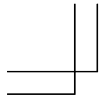

Running LiveUpdate Automatically

The Automatic LiveUpdate automatically updates the definition file.



Be sure to complete the Norton AntiVirus wizard before going on these steps.

1. Click *start – All Programs – Norton AntiVirus – Norton AntiVirus 2004*.
2. Click *Automatic LiveUpdate* in the *Norton AntiVirus Subscription* field.
3. Click the *Enable* button.

Norton AntiVirus Update Service

Norton AntiVirus software scans for virus by means of a virus definition file allowing the software to identify and block a particular virus. To protect the computer against new viruses, the virus definitions and application need to be kept current. The software automatically checks the web and updates the definition file when needed. Free update service will be provided within ninety days since the software becomes enabled. After the free service is over, one-year paid update service can be available. Refer to <http://www.symantec.com>.

Scanning Viruses

By default settings, the Norton AntiVirus software automatically scans the computer once a week. To manually scan viruses infecting the computer, follow the instructions below.



Be sure to complete the Norton AntiVirus wizard before going on these steps.

1. Click *start – All Programs – Norton AntiVirus – Norton AntiVirus 2004*.
2. Click *Scan for Viruses* in the Norton AntiVirus menu.
3. Double-click the option in the *Task* column and then, follow the on-screen instructions.

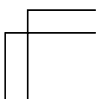
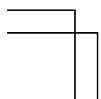

Data Backup and Restore

Your important data such as e-mails or files is stored on the hard disk of the computer. Backing up the data in another place is one of the ways that protect your data against any disaster, data corruption or data erase, for example.

Backing Up Your Data

The *File and Settings Transfer Wizard* can help you to back up several files and settings at one time. To open the wizard, follow the instructions below.

1. Connect the backup device or media to the computer.
2. Click *start – All Programs – Accessories – System Tools – File and Settings Transfer Wizard*.
3. Follow the on-screen instructions.

Restoring Your Data

You can also use the *File and Settings Transfer Wizard* to restore your data or settings from the backup media to the hard disk.



When restoring your backup data, the wizard asks you if you try to overwrite a file that already exists on the hard disk. Make sure the backup data is the one you want before overwriting the existing file.

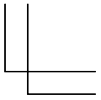
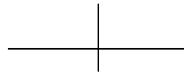
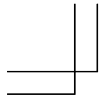

Re-installation Instructions

Refer to this section to re-install the system of the computer.



- *The reinstallation process will overwrite all information in the C and D drives of the hard disk and restore the hard disk drive to its factory configuration.*
- *The necessary reinstallation data is on the hard disk of the computer. Never modify or delete the data. Without the data, you cannot restore the computer.*
- *Do not change the setting of the hard disk partition. The change may result in deleting the reinstallation data. Without the data, you cannot restore the computer.*
- *If you have installed commercial data recovery software on the computer, never perform the reinstall process until you uninstall the recovery software, which may rewrite the MBR* of the hard disk. If the MBR is rewritten, you may not be able to reinstall the system. (* Master Boot Record: a sector on the beginning of a hard disk drive that contains a sequence of commands necessary for booting an operating system)*

To recover your hard disk, you will use PowerQuest®EasyRestore™. Before starting re-installation, read the following End User License Agreement first.

PowerQuest(R) EasyRestore (TM) End User License Agreement

IMPORTANT: Read this before using your copy of PowerQuest software.

This document is a legal agreement between you, the "end user," and PowerQuest Corporation. Use of the software indicates your acceptance of these terms. As used in this License Agreement, the term "Software" means the EasyRestore software included on the CD provided with this License Agreement.

1. PROPRIETARY RIGHTS. The Software is a proprietary product of PowerQuest Corporation ("PowerQuest") or its licensors and is protected under U.S. copyright laws and international treaty provisions. Ownership of the Software and all copies, modifications, and merged portions thereof shall at all times remain with PowerQuest or its licensors.

2. GRANT OF LICENSE. The Software is being licensed to you, which means you have the right to use the Software only in accordance with this License Agreement. The Software contains pre-installed software for disaster recovery purposes. The Software is only authorized for distribution together with a specific

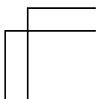
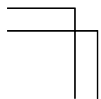

computer. This License authorizes you to use the Software for disaster recovery purposes only, to restore the hard disk image contained on the CD to the computer with which the CD and Software were originally shipped.

3. NONPERMITTED USES. Without the express permission of PowerQuest, you may not (a) use, copy, modify, alter, or transfer, electronically or otherwise, the Software or documentation except as expressly permitted in this License Agreement, or (b) translate, reverse program, disassemble, decompile, or otherwise reverse engineer the Software.

4. TECHNICAL SUPPORT. PowerQuest is NOT responsible to provide technical support. Any and all technical support questions, regarding the Software, should be referred to the place of purchase.

5. U.S. GOVERNMENT RESTRICTED RIGHTS. If you are acquiring the Software on behalf of any unit or agency of the United States Government, the following provision applies: It is acknowledged that the Software and the documentation were developed at private expense and that no part is in the public domain and that the Software and documentation are provided with RESTRICTED RIGHTS. Use, duplication, or disclosure by the Government is subject to restrictions as set forth in subparagraph (c)(1)(ii) of the Rights in Technical Data and Computer Software clause at DFARS 252.227-7013 or subparagraphs (c)(1) and (2) of the Commercial Computer Software-Restricted Rights at 48 CFR 52.227-19, as applicable. Contractor/manufacturer is PowerQuest Corporation/P.O. Box 1911/Orem, UT 84059.

6. NO WARRANTY. The Software is being provided to you AS IS. PowerQuest does not warrant the Software to end users. If the Software fails to perform substantially in accordance with the documentation provided to your hardware supplier, PowerQuest will repair or replace the copy of the Software provided to your hardware supplier and will authorize your hardware supplier to provide such repaired or replaced Software to you without charge.

7. LIMITATION OF LIABILITY. NEITHER POWERQUEST NOR ITS SUPPLIERS SHALL IN ANY EVENT BE LIABLE FOR ANY DAMAGES WHATSOEVER ARISING OUT OF OR RELATED TO THE USE OF OR INABILITY TO USE THE SOFTWARE, INCLUDING BUT NOT LIMITED TO DIRECT, INDIRECT, SPECIAL, INCIDENTAL, OR CONSEQUENTIAL DAMAGES, AND DAMAGES FOR LOSS OF BUSINESS PROFITS, BUSINESS INTERRUPTION, LOSS OF BUSINESS INFORMATION, OR OTHER PECUNIARY LOSS, EVEN IF POWERQUEST CORPORATION HAS BEEN ADVISED OF THE POSSIBILITY OF SUCH DAMAGES, WHETHER SUCH LIABILITY IS BASED ON CONTRACT, TORT, WARRANTY, OR ANY OTHER LEGAL OR EQUITABLE GROUNDS. BECAUSE SOME STATES DO NOT ALLOW THE EXCLUSION OR LIMITATION OF LIABILITY FOR CONSEQUENTIAL OR INCIDENTAL DAMAGES, THE ABOVE LIMITATION MAY NOT APPLY TO YOU.

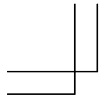

8. NO WAIVER. Any failure by either party to this agreement to enforce a specific part of the agreement in a specific situation is not a waiver of rights under the agreement. The party may still enforce the rest of the agreement in that situation and may still enforce some or all of the agreement in other situations.

9. This License Agreement constitutes the entire agreement between you and PowerQuest pertaining to its subject matter. This License Agreement is governed by the laws of the State of Utah. Any litigation arising from this license will be pursued only in the state or federal courts located in the State of Utah.

Copyright 1994-2005, PowerQuest Corporation. All rights reserved. U.S. Patents 5,675,769; 5,706,472; and 5,930,831; other patents pending in the U.S.A. and elsewhere. PowerQuest is a registered trademark and EasyRestore is a trademark of PowerQuest Corporation.

Recovery Options

You can format the hard disk and re-install the preinstalled software and set the status of the computer to the same configuration as you used for the first time. There are two ways to recover the hard disk drive(s) of the computer: via hard disk and via recovery CD. The former saves your time, while the latter secures the re-installation data from potential loss or corruption. The later section describes the specific steps for each way.



Before you recover via recovery CD, you need to write the recovery data already installed on the computer onto blank CD-R discs. (Refer to the later section.) You are allowed to create the recovery CD only once.

Preparation for Re-installation

The following items are necessary for re-installation.

Via Hard Disk

- Operation Manual

Via Recovery CD

When you recover first time:

- Operation Manual
- Four blank 650MB or 700MB CD-R discs for creating recovery CDs

When you recover after preparing the recovery CDs:

- Operation Manual
- The created recovery CDs

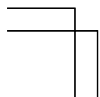

Backing Up Data

Before formatting the hard disk, you should back up your data. For details on how to back up your data, refer to *Data Backup and Restore* section on the earlier page.

Selecting Way to Recover Your System

The computer has two drives (C: and D:) when it was shipped from the factory. You can select the way to recover your system.

- *Recovers C: drive only. (Recommended)*
This process will format C: drive only and recover C: drive to the same status as shipped from the factory. Nothing will be performed to D: drive. The volume of the drives will not be changed and will keep current one.
- *Recovers both C: and D: drive.*
This process will format both C: and D: drives, and contents of the hard disk will be restored to its original state in C: drive. The volume of the drives will be back to the same as you used for the first time. This choice will not allow you to recover your system from the hard disk once the recovery process is completed.

Formatting Drives and Re-installing Windows



The formatting and re-installing process will restore the hard disk drive to its factory configuration. To ensure the computer is safe, enable the virus protection/cleaner software and update the virus definition file to the latest one. Also, the Windows Update should be done for virus prevention. (Refer to the Virus Protection section.)

Via Hard Disk

With this way, recovery will come from data already installed on the computer rather than from external media such as CD.



Note that if there is any chance of the data loss or corruption, you cannot format the hard disk drive(s) and reinstall Windows.

1. Make sure the computer is turned off.
2. If any peripheral devices are connected to the computer, disconnect them.
3. Connect the AC adapter.

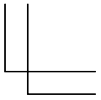
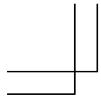

Be sure to connect the AC adapter. If the battery power becomes significantly low, the installation process will be canceled.

4. Turn on the computer. When the message *<F2> to enter System Configuration Utility* appears on the bottom left of the screen, press **F2**. Then, the Setup Utility will open.
5. In the *Exit* menu, select *Load Setup Defaults*; then, press **Enter** twice.
6. In the *Exit* menu, confirm *Exit Saving Changes* is highlighted and press **Enter** twice.
7. The system will restart. When the message *Press F10 to Recover* appears on the upper left of the screen, press **F10**.



The message stays there for two seconds.

8. Read the message on the screen, and select the way to recover your system; then, press **Enter**.
9. Read the message and select *Continue*; then, press **Enter**. The formatting and re-installation will start.



Although the pointer may be shown on the screen, never touch the keyboard or the mouse during recovery except when the message prompts you to. If you touch them, the re-installation will be canceled.

10. When the hard disk has been recovered successfully, the system will restart automatically.
11. Set up Windows XP by following the on-screen instructions. After you complete the Windows setup, be sure to set date and time.

Via Recovery CD

Recovery CDs do not come with the computer. First, you need to copy the recovery data onto CD-Rs and then, recover the system with them.

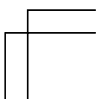
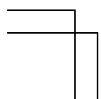



- You will have only one duplicate.
- Even if you cancel the CD burning process, you can create the recovery CDs by starting at the first step.
- You can recover your system via hard disk after creating the recovery CDs.

Creating Recovery CD

To create the recovery CDs, you will use *Bootable CD Creator*. Read the following End User License Agreement first.

Enterprise Corporation International Software License Agreement

This End-User License Agreement (“the Agreement”) is a legal agreement between you, the “end user,” and Enterprise Corporation International (“ECI”) for the ECI product, which includes a computer program (Bootable CD Creator), data, and manuals (“SOFTWARE PRODUCT”). Ownership of the SOFTWARE PRODUCT shall at all times remain with ECI. The SOFTWARE PRODUCT and accompanying documentation are licensed to you, which means you have the non-transferable and non-proprietary right to use the SOFTWARE PRODUCT in accordance with this Agreement. The SOFTWARE PRODUCT and any accompanying documentation are proprietary products of ECI or its licensors and are protected by United States copyright laws and international copyright treaties. Use of the enclosed software indicates your acceptance of these terms.

Intended Purpose:

The SOFTWARE PRODUCT is installed on and shipped with a computer manufactured by Sharp. You may use the SOFTWARE PRODUCT only for making a Bootable CD from the recovery image file that is pre-installed on the hard disk. You may use the SOFTWARE PRODUCT only on the computer with which this SOFTWARE PRODUCT is provided.

You may not:

1. Copy the SOFTWARE PRODUCT, in whole or in part, to another media except for installation.
2. Share the license for the SOFTWARE PRODUCT or use it concurrently on different computers.
3. Alter, transfer or sell (including e-sales through the Internet) the SOFTWARE PRODUCT and/or its copy to a third party, in whole or in part.
4. Delete or change the notice of copyright contained in the SOFTWARE PRODUCT.
5. Reverse engineer, disassemble, or decompile the SOFTWARE PRODUCT.
6. Create source code for the SOFTWARE PRODUCT from the object code.
7. Use any portion of the SOFTWARE PRODUCT within any other program.
8. Install or run the SOFTWARE PRODUCT over the Internet for use by multiple users.

Term: This Agreement is effective from your date of purchase or the date you opened the package and shall remain in force until terminated. Upon termination of this Agreement, you must destroy all copies of the SOFTWARE PRODUCT and all accompanying documents. ECI may terminate this Agreement if you fail to comply with its terms and conditions.

Limited Warranty: ECI warrants that the SOFTWARE PRODUCT will perform substantially in accordance with the accompanying documentation. The warranties set out in this agreement are in lieu of and exclude all other warranties not expressly set forth herein, whether express or implied, including but not limited to any warranties of merchantability, fitness for a particular purpose, or warranties arising from usage of trade or course of dealing.

Limitation of Liability: In no event shall ECI or Sharp be liable for any special, incidental, indirect, or consequential damages, or for damages for loss of business profits, business interruption, loss of business information, or other pecuniary loss, even if ECI or Sharp has been advised of the possibility of such damages.



Before creating the recovery CDs, follow the instructions below:



- *Prepare four blank 650MB or 700MB CD-R discs.*
- *Connect the AC adapter. If the battery is discharged, the operation will stop and fail.*
- *Disable the power management. See Power Management section in Chapter 2.*
- *Close all of the unnecessary or the automatic start-up applications.*
- *Disable the wireless LAN antennas. See Wireless LAN section in Chapter 4.*
- *Disable the screen saver. See the Changing Wallpaper and Setting Screen Saver section in Chapter 1.*

Disabling Auto Protect of Norton AntiVirus

Before creating the recovery CDs, disable the Auto Protect function of Norton AntiVirus.

1. Right-click the Norton Antivirus icon () on the taskbar.
2. Click the *Configure Norton AntiVirus*.
3. Clear the boxes of *Enable Auto-Protect* and *Start Auto-Protect when Windows starts up* in the *How to stay protected* field.
4. Click *OK*.
5. Click *OK*.



The icon () will change to ().

Creating Recovery CD

1. Connect the AC adapter to the computer.



Be sure to connect the AC adapter. If the battery is completely discharged, the burning CD process will be stopped.

2. Insert a blank CD-R into the optical drive.



If a dialog box or window appears, close it.

3. Click *start – All Programs – Create Product Recovery CD*.
4. In the *Bootable CD Creator SE1.1* window, select the appropriate speed from the *speed* pull-down menu, then, click *Create Recovery Disc*.
5. Read the message on the screen and then, click *Yes*, then, *OK*. The burning process will start.



Never touch the keyboard, the mouse or the screen during burning process except when the message prompts you to. If you touch them, the burning process may be stopped.

6. Replace the CD-R by following the instructions on the screen. Assign names to each CD-R in the order of burning so that you will set them in correct order when using them.



If a window or dialog box opens, close it.

7. When you see the message *Disc creation complete* on the screen, click *OK*, then, *Close*.
8. Click *Yes* and remove the CD-R from the optical drive.

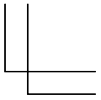
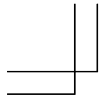



- *Store the burned discs in a secure place.*
 - *Keep your discs away from direct sunlight, heat and excessive moisture.*
-

9. Restart the computer.

Enabling Auto Protect of Norton AntiVirus

1. Right-click the Norton Antivirus icon () on the taskbar.
2. Click the *Configure Norton AntiVirus*.
3. Check the boxes of *Enable Auto-Protect* and *Start Auto-Protect when Windows starts up* in the *How to stay protected* field.
4. Click OK.
5. Click OK.



The icon () will change to ().

6. Turn off the computer. After more than ten seconds, turn it on again.

Recovering with Recovery CD

The first three created discs will be used for recovering the system. The others have drivers and application software.



When you format entire of the hard disk drive (both C: and D: drives), the recovery data installed in it will be eliminated. Therefore you will not be able to recover your system via hard disk.

1. Make sure the computer is turned off.
2. If any peripheral devices are connected to the computer, disconnect them.
3. Connect the AC adapters to the computer and then, turn it on.



Be sure to connect the AC adapter. If the battery is completely discharged, the installation process will be canceled.

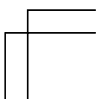
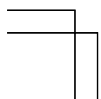

4. When the message *<F2> to enter System Configuration Utility* appears, press **F2**. The Setup Utility will open.
5. Insert the Recovery CD disc 1 into the optical drive.
6. In the *Exit* menu, select *Load Setup Defaults*; then, press **Enter** twice.
7. In the *Boot Sequence* of the *Main* menu, select *CD-ROM Drive* in the *1st Boot Device* field and *Hard Disk Drive* in the *3rd Boot Device* field.
8. Click *OK*.
9. In the *Exit* menu, confirm *Exit Saving Changes* is highlighted and press **Enter** twice.
10. Read the message on the screen, and select the way to recover your system; then, press **Enter**.



When you select Recovers both C: and D: drive, the recovery process will delete the recovery data installed in the hard disk. Therefore you will not be able to recover your system from the hard disk.

11. Read the message and select *Continue*; then, press **Enter**. Follow the on-screen instructions for replacing the recovery CDs.



Although the pointer may be shown on the screen, never touch the keyboard, the mouse or the screen during recovery except when the message prompts you to. If you touch them, the re-installation will be canceled.

12. After the recovery process is complete, the system will restart automatically. When the message *<F2> to enter System Configuration Utility* appears, press **F2**. The Setup Utility will open.
13. In the *Exit* menu, select *Load Setup Defaults*; then, press **Enter** twice.
14. In the *Exit* menu, confirm *Exit Saving Changes* is highlighted and press **Enter** twice. The system will restart.
15. Set up Windows, following the instructions on the screen. Make sure to set date and time.

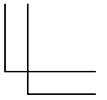
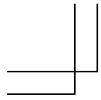

Installing Application Software

The preinstalled applications are stored in fourth recovery CD if you have completed the recovery CD creation process.

When accidentally uninstalling a preinstalled application(s), reinstall it from the recovery CD.



*For installation of WordPerfect® Office 12, the serial number is needed.
Type the following number.
Serial Number: WO12WRX-0000027-NDQ*

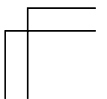
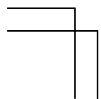
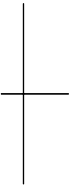
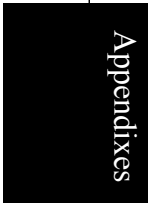
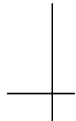

Specifications

Parts		Specifications
Operating System		Microsoft® Windows® XP Home Edition Service Pack 2 with Advanced Security Technologies* ¹
CPU		AMD Mobile Athlon™ XP-M 2400+ processor AMD PowerNow!™ Technology Support
Primary Cache		256 KB (integrated in CPU)
Secondary Cache		512 KB (integrated in CPU)
Memory	Main	512MB DDR SDRAM (PC2100) standard, expandable to 768MB* ²
	Video	8/16/32MB shared with system memory (Default: 32MB)
Display	Panel	12.1"XGA TFT LCD
	Video controller	S3 ProSavage8 (Integrated in KN266 chipset)
	Resolution/color	-Resolution: 1024x768 (XGA) -256K /16M color in LCD
Keyboard		IBM compatible keyboard
Pointing device		Intelligence Glide pad with 1 button(See-Saw type)
Drive	Hard disk	Approx. 60 GB* ³
	Floppy disk (option/external)	USB interface 3.5", 1.44MB/720KB
	Optical* ⁴	CD-R/RW& DVD-ROM Drive Writing* ⁵ : CD-R:24x(Max.) Re-writing* ⁵ : CD-RW:24x(Max.)* ⁶ Reading: CD-ROM:24x(Max.), CD-R: 24x(Max.), CD-RW: 24x(Max.) DVD-ROM: 8x(Max.), DVD-R: 4x(Max.), DVD-RW: 4x(Max.), DVD+R: 4x(Max.), DVD+RW: 4x(Max.), DVD-RAM:2x(Max.)
PC card slot		Type II × 1 (PC Card Standard compliant), CardBus Port supported
Audio system		Stereo 2 speakers (1W output), Built-in AC-link Audio Controller (Define Sound chipset) AC'97 compliant
I/O ports	Audio	Headphone/ audio output jack (stereo), external microphone jack,
	Video	VGA
	Others	USB (2.0) x 4
Modem		RJ-11 modem x1 (V.90 standard. No support for K56Flex, V92)
Wireless LAN	Radio Frequency	IEEE 802.11b (DSSS), IEEE802.11g (OFDM) compliant Wi-Fi compliant
	Operating Channels	11 channels
LAN		100 BASE-TX/10 BASE-T
Power	AC adapter* ⁷	100-240V, 50-60 Hz
	Battery	Rechargeable Li-ion battery
	Battery life* ⁸	Approximately 2.0 hours
	Battery charging time* ⁹	Turned off/hibernation: About 4 hours Turned on: About 6 hours
Power Consumption		Max. 60 W
Dimensions		11.1" wide x 10.4" deep x 0.89" (min.)/1.32" (max.) high (281mm wide x 262mm deep x 22.5mm (min.)/33.5mm (max.) high) No protuberance is included.
Weights		About 5.07 lbs (2.3 kg)
Operating environment	Temperature	10°C to 35°C (50°F to 95°F)
	Humidity	20% to 80% (non-condensation)

Software	Network Setup Utility 2, Norton AntiVirus™ 2004, WinDVD® 5, Drag'n Drop CD+DVD ver.4, WordPerfect® Office 12, Adobe® Reader® 6, etc.
----------	--------------------------------------------------------------------------------------------------------------------------------------

- *1 This model (PC-MC24) does not support other operating systems than the pre-installed one.
- *2 To upgrade the memory size, you need to replace the preinstalled 256MB memory module with a new one.
- *3 Hard drive capacity is calculated as 1GB = 10⁹ bytes. 1GB equals one billion bytes when referring to hard drive capacity. Windows OS displays 55.8 GB as the total hard drive capacity. (C: Approx. 29.2 GB, D: Approx. 21.6 GB and rest reserved as recovery image.)
- *4 Supporting the buffer underrun protection technology which prevents the buffer underrun error occurred when the optical drive writes too fast for the buffer to supply data or if some other application is being used. (Buffer is the storage place of the data read from the hard drive or another media and supplies the data to the recording media smoothly.)
- *5 The optical drive adopts the lower maximum writing speed of those of the optical drive and disc.
- *6 8x/10x /24x speed CD-RW writing/re-writing requires High Speed CD-RW media.
- *7 For the provided AC power cord, the maximum allowable voltage is limited to 125V.
- *8 Battery life is based on BAPCo® MobileMark™ 2002. Battery life will vary based on many factors including screen brightness, applications, features, battery conditioning, power management and other customer preferences.
- *9 Charging time varies depending on usage.

Appendixes



Troubleshooting

This chapter describes how to troubleshoot computer problems.

Common Problems

Problems with your computer can be caused by something as minor as an unplugged power cord or as major as a damaged hard disk drive. The information in this troubleshooting section is designed to help you find and solve minor problems. If you still have a problem after trying all the suggested remedies in this chapter, contact your dealer or call: 1-800-BE-SHARP(237-4277).

The problems that you might encounter can be divided into two basic categories: hardware and software. Hardware problems can be further divided into being of an electrical or a mechanical nature. You will know you have a hardware problem if, for example, the screen is blank, or your computer cannot recognize the disk drives.

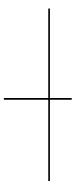

Software problems can occur at several levels. Both your operating system and your software application programs are capable of generating errors and error messages. If you encounter a software error, try to determine if the error message is from your operating system or from an application program, and refer to the appropriate manual for possible remedies.



You can also refer to the Windows help program to solve the problem. To access the program, click *start – Help and Support*. It also gives you troubleshooting tips and an index.

Successful troubleshooting is the result of careful observation, deductive reasoning, and an organized approach to solving the problem. If you encounter a problem, begin by performing a careful visual inspection. Check the exterior of your computer first. If no lights are displayed, check the battery charge or power outlet, the plug and power cord, and any power switches that may affect your computer. If your computer has been connected to any peripheral devices, look for loose or disconnected cables. You may also need to check the fuses and breakers in your electric box. A few common problems and suggested solutions are presented in the examples that follow.

Troubleshooting

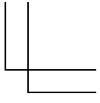
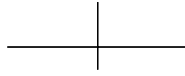
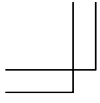

Trouble when Starting

Why doesn't the power indicator or the battery indicator turn on?

- Make sure the AC adapter is correctly connected to the AC adapter jack of your computer.
- Make sure the AC power cable is correctly connected to a live wall outlet. Connect another electric equipment to the wall outlet and check whether it is live or not.
- Make sure the battery pack is correctly installed and charged.
- If the battery pack is discharged, connect the AC adapter.
- If all the steps above failed, follow the instructions on *Why doesn't the keyboard or the touchpad function?*

Why do I get the message *Invalid system disk*?

- You may have inserted a non-bootable disk in the optional external floppy disk drive unit (either a defective disk or one without an installed operating system). Remove the disk.

Why can't I boot from the floppy disk?

- Make sure that the optional external floppy disk drive unit is correctly connected to your computer.
- Check whether the floppy disk set to the optional external floppy disk drive unit contains a system disk.
- Check whether *USB Emulation* in the *Main* menu of the Setup Utility is enabled. (Refer to the *Main Menu* in Chapter 5.)
- Check whether *Floppy Disk Drive* is at the top in the *Boot Sequence* in the *Main* menu of the Setup Utility is selected. (Refer to the *Main Menu* section in Chapter 5.)

Troubleshooting

Why do I get the message *Operating System not found*?

- The message may appear when the reinstallation has failed. Recover the C and D drives using the created recovery CDs.

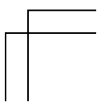
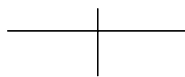
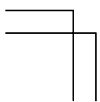

Why do I get the message *Press <F1> to resume, <F2> to setup?*



- The setting of the Setup Utility is deleted. Follow these steps:
 1. Press **F2** key while the message *Press <F1> to resume, <F2> to setup* is appearing.
 2. In the *Exit* menu, select *Load Setup Defaults* and press the **Enter** key to retrieve the default value.
 3. Confirm *Yes* is highlighted and then, press the **Enter** key.
 4. Set the desired values in the Setup Utility or just leave the default value.
 5. In the *Exit* menu, select *Exit Saving Changes* and then, press the **Enter** key.
 6. Confirm *Yes* is highlighted and then, press the **Enter** key.
 7. On Windows, click *start – Control Panel*.
 8. Click *Date, Time, Language, and Regional Options*.
 9. Click *Change the date and time*.
 10. In the *Date and Time Properties* dialog box, set the current date and time; then, click *OK*.
 11. Close the dialog box.
 12. Make an appropriate setting on the Setup Utility, if necessary. If you want to keep the default settings, no setting is needed.

Trouble with Display

See also the *Adjusting Display* section in Chapter 1 and the *External Display* section in Chapter 3.

Why is the screen blank?

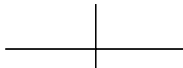
- Press any key to see if any power management feature has turned off the screen to save power.
- See the power indicator to check whether your computer is turned on.
- If you are using a battery pack, make sure it is correctly installed and has a charge remaining.
- Make sure the LCD screen is selected as the display by pressing **Fn+F5** (⏻).
- Check whether the display is on by pressing **Fn+F11** (⏻).

- 
- 
- 
- If you still have the problem after trying the above, follow the steps in *Why doesn't the keyboard or the touchpad function?*

Why does the external monitor display nothing/why is the image on it distorted?

- Confirm the monitor is turned on.
- Confirm the monitor is connected correctly.
- Make sure the external monitor is selected as the output display by pressing **Fn+F5** (⌘).
- If you use **Fn+F5** (⌘) to change the display, the image may be distorted. Press **Fn+F5** (⌘) again to return the previously selected display and use the *Display Properties* dialog box to change it again.
- Make sure the value of the *Screen resolution* field in the *Settings* tab of the *Display Properties* is same as or lower than the resolution of the external monitor.
- Make sure the external monitor is not near any electric devices having strong magnetic fields such as a TV set or radio.
- Do not share an outlet with a TV set or radio.





Why can't I change the display with the Fn+F5 (⌘) keys?

- When playing the animation or game, the **Fn+F5** (⌘) keys combination may not work. Close the currently running application.
- When running DOS in the full screen mode, the **Fn+F5** (⌘) keys combination may not work.
- Use the *Display Properties* dialog box to change it.
- When you select the *Extended Desktop* mode, the **Fn+F5** (⌘) keys combination does not work.

Trouble with Keyboard/Touchpad

Why doesn't the keyboard or the touchpad function?

- Try the following in this order:

- 
- 
- 
1. Press **Ctrl+Alt+Delete** and select the *Applications* tab of the *Windows Task Manager* dialog box. Click the program name that hangs up, then, *End Task*. If this does not solve the problem, select the *User* tab and click *Disconnect* or *Logoff* of the *Windows Task Manager* dialog box, then *Yes*.
 2. If the step 1 fails to work, press the power button for more than four seconds to turn off the system. Ten seconds later, turn your computer on.
 3. If pressing the power button fails to turn off your computer, remove the AC adapter, then, the battery pack. Ten seconds later, reinstall the battery pack, connect the AC adapter and then, turn on your computer.

Why does the touchpad malfunction?

- The surface of the touchpad or your palm may be moist or dirty and grease. Wipe the touchpad with a soft, dry cloth.

Trouble with Floppy Disks

Why can't I use a floppy disk?

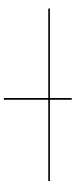
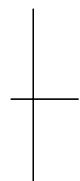
- 
- 
- Confirm the optional external floppy disk drive unit is correctly connected.
 - Confirm the floppy disk is inserted correctly.
 - Confirm the drive or file name is correct.
 - The floppy disk may not be formatted or could be corrupted. Format the disk or use another disk.
 - If you cannot write to a floppy disk, the disk may be write-protected. Eject the disk and ensure that the write-protect tab covers the detection hole.
 - If you cannot write to a floppy disk, the disk may be full. Use another disk.
 - You cannot boot the computer from 720KB (2DD) disks.
 - You cannot format 720KB (2DD) disks.
 - You cannot use the DISKCOPY command on 720KB (2DD) disks.
 - 720KB (2DD) disks are not appropriate to save data.
 - You may not use 720KB (2DD) disks for data transfer with other computers using 1.44MB (2HD) disks.

Trouble with Hard Disk

Why can't I read or write data to/from the hard disk?

- Confirm the drive and file names are correct.
- Confirm the hard disk has sufficient free space.

Trouble with Optical Drive

Why can't I read data from a compact disc or play files?

- Confirm the CD is inserted correctly.
- Confirm the drive and file names are correct.
- Confirm the CD is not dirty or scratched.
- Confirm the CD or files are supported.

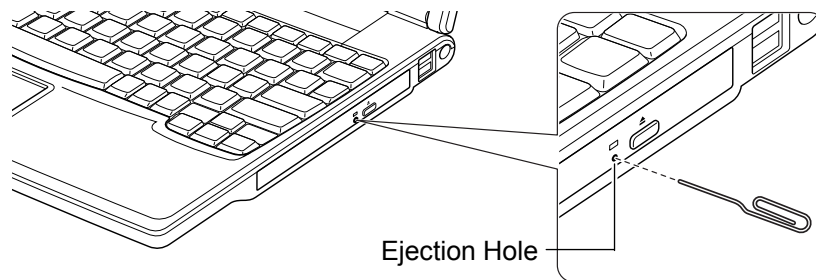

Why does not the drive open?

- Confirm your computer is turned on.
- When your computer is turned off, insert a fine rod into the drive tray ejection hole.



Why can't I play the disc?

- Confirm the disc is properly set onto the optical drive.
- The disc may be dirty. Clean it with soft cloth.





Why can't I read/write data from/onto a disc or play files?

- Confirm your computer is turned on.
- Confirm the disc is inserted correctly.
- Confirm the drive and file names are correct.
- Confirm the disc is not dirty or scratched.
- Confirm the disc or files are supported.

Why doesn't the DVD video play smoothly?

- Make sure your computer is correctly connected to an AC source.
- The disc may be dirty. Clean it with a soft cloth.
- Power management may be working. Disable it.

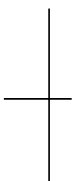

Why isn't the optical drive recognized?

- 
- 
- If your computer is turned on with a DVD disc inserted in the drive, the drive may not be recognized. In this case, turn off your computer and open the disc tray by the way on *Why does not the drive open?* on the previous page. Remove the disc from the drive; then turn on your computer again.

Trouble with Communication

Why can't I communicate through the built-in modem?

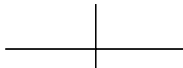

- Confirm the telephone line is properly connected to the modem jack.
- Confirm the dial setting (pulse or tone) of Windows XP and/or communication software is matched with the telephone line.
- If you set your connection status using *New Connection Wizard*, check *Use dialing rules* in the *Properties* dialog box of that connection status. (Refer to *Internet Connection* section of Chapter 4.)
- Confirm the country/region setting is appropriate.
- Confirm the network configuration is appropriate.
- Confirm the user name or password is correct.
- Confirm the COM port in the communication software is set appropriately.

- 
- 
- 
- Turn off the power management in Windows.
 - If an unusual device is attached to the line you are connecting to, the modem may not function properly. Remove the device or contact the dealer of the device.
 - If your computer is connected to a PBX, consult the PBX maintenance staff or its service company. If the electric characteristics of your PBX are different from those of a regular analog line, the modem will not function properly. If you connect the modem to a digital PBX, both the modem and the PBX may be damaged.

Why is the access speed so slow?

- Close the currently running applications.
- Try to connect another ISP (Internet Service Provider), or try to connect in some other time.

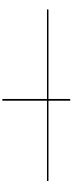
Why can't I access the LAN?

- 
- 
- Confirm the cable is properly connected to the LAN jack and the network hub.
 - Confirm the network configuration is appropriate. (Refer to the *Configuring LAN Unit* section in Chapter 4.)
 - Confirm the user name or the password is correct.
 - Reconfigure the network settings by following the Network Setup Wizard.

Why can't I detect the access point on my computer?

- 
- Confirm your computer is enabled for the wireless LAN communication.
 - Confirm the access point is powered on.
 - Confirm the antenna indicator is lit.
 - Restart your computer.

Why can't I connect to the network via an access point?

- Confirm the wireless LAN antennas are enabled. When the antenna indicator lights green, the antennas are enabled. If not, press **Fn+F1** () keys to activate them.

- Confirm *Any available network (access point preferred)* is selected in the *Networks to access* field of the *Advanced* dialog box. (To open the *Advanced* dialog box, refer to the *Communicating with Other Computers* section in Chapter 4.)
- Confirm the *Network name* of your computer matches that of the access point you want to communicate with.
- Confirm the security settings of your computer equals to those of the access point if the encryption security of the access point is enabled.
 - Reenter the *Network key*.
 - When using the WEP key, confirm the key index is correctly selected.
- When you have more than one access points, your computer may be connected to other than right one you want to access. Follow the steps below.
 1. Right-click the *Wireless Network Connection* icon () on the taskbar; then, click *View Available Wireless Networks*.
 2. Select the desired network in the *Available wireless networks* list; then, connect to the network. (Refer to the *Confirming Status of Wireless Connection* section in Chapter 4.)
- Repair the connection with the following steps.
 1. Right-click the *Wireless Network Connection* icon.
 2. Click *Repair*.
- If there are more than one available access points nearby, they interact in the connection. In this case, the connection speed will become low or the connection will stop.
- You may have accidentally enabled IEEE802.1x authentication. Disable it with these steps.
 1. Click *start – Control Panel*.
 2. Click *Network and Internet Connections – Network Connections*. If Classic view is selected, double-click *Network Connections*.
 3. Right-click *Wireless Network Connection* and click *Properties*.
 4. Click *Wireless Networks* tab, select the network in *Preferred networks* field and click *Properties* button.
 5. Select *Authentication* tab, then, clear the box of *Enable IEEE802.1x authentication for this network*.
 6. Click *OK* twice and close the window.



Why can't I communicate with other computers through wireless LAN?

- Confirm the antennas are enabled with pressing **Fn+F1** () key combination. When the antenna indicator is on, the antennas are enabled. (Refer to the *Activating Antenna* section of *Wireless LAN* in Chapter 4.)
- Confirm each computer is enabled for wireless LAN.
- Confirm *Computer-to-computer (ad hoc) networks only* is selected in the *Networks to Access* of *Advanced* dialog box. (To open the *Advanced* dialog box, refer to the *Communicating with Other Computers* section in Chapter 4.) Also confirm the other computers are in ad-hoc mode.
- Adjust the distance between your computers by bringing your computer closer to others and remove any obstructions that may impede the communication; then, try to connect again.
- Confirm the IP address and the subnet mask of each computer are set correctly.
- Confirm the WEP keys are correctly set to your computer if the WEP security of the communicated computers is enabled.

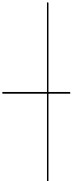



Why is the connection to the access point unstable?

- Follow these steps to reconfigure the wireless LAN settings.
 1. Click *start – Control Panel*.
 2. Click *Network and Internet Connections*.
 3. Click *Network Connections*.
 4. Click *Wireless Network Connection* and the *Change settings of this connection* string in the *Network Tasks* field.
 5. Click the *Configure...* button.
 6. Click the *Advanced* tab and select the *Super Mode* in the *Property* list.
 7. Select *Disabled* in the *Value* pull-down menu.
 8. Click *OK* and close the window.

Troubleshooting

How can I detect the MAC address?

- Follow the instructions below:
 1. Click *start – All Programs – Accessories – Command Prompt*.
 2. Type `ipconfig/all`; then, press **Enter**. The information about IP appears.

- 
- 
- 
3. See the numbers of *Physical Address* in *Ethernet adapter Local Area Connection* section (for LAN) or *Ethernet adapter Wireless Network Connection* section (for Wireless LAN).
 4. Type `exit`; then, press **Enter**.

Trouble with Peripherals

Why don't peripheral devices function?

- Confirm they are correctly connected to your computer.
- Confirm they are Windows XP compliant.
- Confirm drivers necessary for the devices are installed.

Why can't I print?

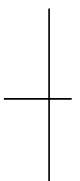
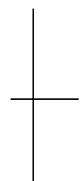
- 
- 
- Make sure the printer is turned on.
 - Check whether your computer and the printer are connected correctly.
 - Check whether the printer is ready to print.
 - Check whether the printer has enough paper.
 - Check whether the printer driver is installed.
 - Click *start - Control Panel - Printers and Other Hardware – Printers and Faxes*. If Classic view is selected, double-click *Printers and Faxes* icon. Confirm your printer is installed. If not, click *Add a printer* of *Printer Tasks* to install it.
 - See also the Windows help program by clicking *start - Help and Support*.

Why don't peripheral devices function correctly?

- Set *System standby/hibernate* to *Never* in the *Power Options Properties* dialog box. If this does not work, set *Turn off hard disks* to *Never*.
- Confirm they are Windows XP compliant.
- Confirm drivers necessary for the devices are installed.

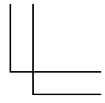
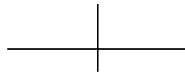
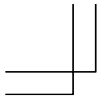

Trouble with Security Settings

Why do I have the message “Your computer might be at risk” each time I boot my computer?

- If you have the message “Automatic Updates is turned off” addition to the above message, turn on the Automatic Updates to enable your computer periodically to update Windows.
- If you have the message “No firewall is turned on” addition to the above message, turn on the Firewall to protect your computer against viruses and other security threats.

Other Troubles

Why is my computer not powered on?



- Follow these steps.
 1. Disconnect the AC adapter.
 2. Remove the battery pack.
 3. After ten seconds later, reinstall the battery pack again.
 4. Reconnect the AC adapter.
 5. Press the power button to turn on the computer.

Why do I get the message *Pop-up blocked* in the information bar?

- The Microsoft Internet Explorer restricts display of pop-ups using the popup blocker function.
 - If you want to have the pop-ups on the current web site;
 1. Start up the Microsoft Internet Explorer.
 2. Click the information bar.
 3. Select “Temporarily Allow Pop-ups” or “Always Allow Pop-ups from this site...”.

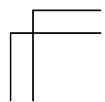
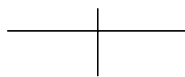
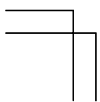
“Always Allow Pop-ups from this site...” will always allow for the permitted site to have pop-up ads.



- 
- 
- 
- If you want to have pop-up ads on the specified web site;
 1. Start up the Microsoft Internet Explorer.
 2. Open the *Tools* menu and select the *Pop-up Blocker – Pop-up Blocker Settings...*
 3. Enter the URL to be permitted in the *Address of Web site to allow* field and then, click *Add*.

Why do I get the message *This site might require the following ActiveX control in the information bar?*

- The Microsoft Internet Explorer restricts display of active contents. You can display the contents by following these steps. Before performing the steps, ensure the safety of the contents.
 1. Click the information bar.
 2. Select *Install ActiveX Control...* from the pop-up menu.
 3. Click *Install*.



Why isn't the web site displayed properly?

- Disable the popup blocker. (Refer to the related section.)
- Install the appropriate ActiveX control application(s).

Why is the e-mail displayed improperly?

- The Microsoft Outlook Express may block images in HTML e-mails. To display the image, follow these steps. (Note that if you click the message, the sender of the e-mail may receive the fact that you open the message. Ensure the safety of the mail before operating these steps.)
 1. Start up the Microsoft Outlook Express.
 2. Select the e-mail containing the image to be displayed.
 3. Click the message displayed in the bar.

Why is the battery pack discharged so quickly?

- Initialize the battery pack.

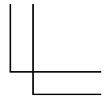
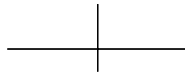
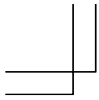

Why is the date or time incorrect?

- Correct the date and time in Windows. Double-click the time appearing on the taskbar and set them in the *Date and Time Properties* dialog box.

Why can't I use a hardware device?

- Make sure the hardware device is not crossed out with an X mark using the following procedure.
 1. Click *start – Control Panel*. Click *Performance and Maintenance*; then, *System*. If the Classic view is selected, double-click the *System* icon.
 2. Click the *Hardware* tab; then, *Device Manager*.
 3. Double-click the device you cannot use and confirm *Use this device (enable)* appears in *Device usage*.

Why can't I produce sound?

- Click or double-click the speaker symbol on the taskbar and check the Windows volume.

Why can't I turn off my computer?

- Follow the instructions on *Why doesn't the keyboard or the touchpad function?*

Why my computer is so hot?

- When charging the battery pack, its surrounding area or the front of the keyboard may become hot, but this is not a problem.

Why can't I record the sound from the microphone?

- Follow the instructions below:
 1. Double-click the speaker symbol on the taskbar.
 2. Click *Options* and select *Properties*.
 3. Select *Recording* in *Adjust volume* and confirm *Microphone* is checked in *Show the following volume controls*, then click *OK*.
 4. Confirm *Select* is checked in *Microphone* of the *Recording Control* dialog box.
 5. Close the *Recording Control* dialog box.

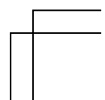
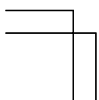



Why can't find the drivers and applications?

- You may accidentally remove them. Refer to the following to retrieve them.
 - The drivers are stored on the fourth recovery disc if you have created the recovery CDs and in the *DRIVERS* folder on your computer. To open the folder;
 1. Click *start – My Computer*.
 2. Double-click *SHP_V2310U(C:) – Program Files – SHARP – DRIVERS*.
 - The applications are stored on the fourth recovery disc if you have created the recovery CDs. Without the recovery CDs, you need to reinstall the operating system from the hard disk.

If you are not sure how to install them, consult local service staff.

What is the serial number for WordPerfect® Office 12?

- When installing the WordPerfect® Office 12 from the created CD, you must enter the following serial number to complete the installation.

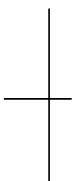

Serial Number: WO12WRX-0000027-NDQ

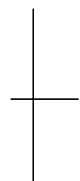

Troubleshooting

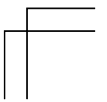
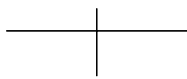
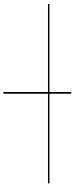
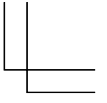
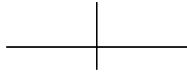
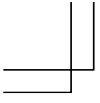

Index

A

- AC adapter
 - connecting, 1-1
 - using, 1-5
- Account
 - creating, 1-19
 - switching, 1-19
- Antenna, 4-12
- Audio
 - controlling output volume, 1-16

B

- Backing up data, A-13
- Battery pack
 - backup battery, A-4
 - changing, 2-4
 - charging, 2-2
 - checking level, 2-2
 - conditioning, 2-4
 - indicator, 1-4, 2-3
 - low battery indication, 2-3

C

- Cleaning
 - computer, A-8
- CD
 - handling, 1-10
 - inserting, 1-11
 - removing, 1-12
 - troubleshooting, T-6
- CD-R/RW, 1-13
- Computer name, 4-7

D

- Display
 - changing brightness, 1-17
 - changing resolution, 1-17
 - changing number of colors, 1-17
 - switching display, 1-10, 3-7
 - troubleshooting, T-3
 - turning off, 1-10
- DVD
 - handling, 1-10
 - inserting, 1-11
 - removing, 1-12
 - troubleshooting, T-6
- DVD video
 - parental control, 1-15
 - playing, 1-13
 - region code, 1-14
 - troubleshooting, T-7

E

- External monitor
 - connecting, 3-6
 - disconnecting, 3-7
 - switching display, 1-10, 3-7

F

- File sharing
 - copying, 4-8
 - sharing, 4-8
- Floppy disk
 - ejecting, 3-5
 - handling, 3-4
 - inserting, 3-4
 - formatting, 3-5
 - troubleshooting, T-5
- Floppy disk drive (external)
 - connecting, 3-3
 - removing, 3-5

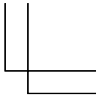

H

Hard disk drive
troubleshooting, T-6

I

Indicators
antenna, 4-12
power, 1-3, 4
battery status, 1-4, 2-3
status, xxii

K

Keyboard
application key, 1-9
function keys, 1-9
special keys, 1-9
troubleshooting, T-4
windows key, 1-9

L

LAN
configuring network, 4-6
configuring unit, 4-5
connecting to wired network, 4-4
troubleshooting, T-8

M

Modem
configuring, 4-3
connecting to telephone line, 4-2

N

Network Setup Utility
auto-switching, 4-21
loading, 4-20
running, 4-20
switching, 4-21

O

Optical Drive
using, 1-10
troubleshooting, T-6

P

Passwords
changing, 1-21, 5-5
deleting, 1-21, 5-5
setting, 1-20, 5-5
PC cards
ejecting, 3-12
inserting, 3-11
Peripherals
audio equipment, 3-8
connecting guidelines, 3-1
external monitor, 3-6
headphones, 3-9
microphone, 3-9
PC cards, 3-11
printer, 3-14
speaker, 3-8
troubleshooting, T-11
USB device, 3-10
Power
choosing AC or battery, 1-4
indicator, 1-3, 4
Power management
disabling, 2-12
stopping power supply to display, 2-7
stopping power supply to hard disk, 2-7
system hibernate, 2-9
system standby, 2-9
Printer, 3-14

R

Resetting
power switch, 1-6
Restoring data, A-13
Re-installation A-14
common information, 1-6
creating recovery CDs, A-19
hard disk recovery, A-17
preparation, A-16
recovery option, A-16
CD recovery, A-22

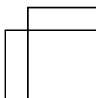
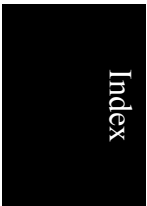
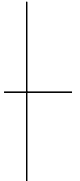
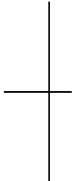

S

Screen Saver, 1-18
Setup utility
 advanced menu, 5-4
 changing setting, 5-2
 entering and exiting, 5-2
 exit menu, 5-6
 main menu, 5-3
 running, 5-1
 security menu, 5-4
Security cable, A-8
Specifications, A-25
System standby
 about, 2-9
 generating conditions, 2-10
 resuming from, 2-9
System hibernate
 about, 2-9
 generating conditions, 2-10
 resuming from, 2-9
 supporting, 2-10
Status indicators, xxii

T

Touchpad
 changing configuration, 1-9
 clicking and double-clicking, 1-8
 drag and drop, 1-8
 enabling, 1-7
 scroll, 1-9
 troubleshooting, T-4
Troubleshooting
 common problems, T-1
 communications, T-7
 display, T-3
 Internet Explorer, T-12
 installing drivers/applications, T-15
 floppy disk drive, T-5
 hard disk drive, T-6
 keyboard or touchpad, T-4
 modem, T-7
 optical drive, T-6
 peripherals, T-11
 wired LAN, T-7
 wireless LAN, T-8

U

USB device, 3-10

V

Virus Protection, A-10

W

Wallpaper, 1-18
Windows
 updating, xiii, A-10
 firewall, xiii
 Security Center, xiii
Wireless LAN
 activating antenna, 1-9, 4-12
 communicating between computers, 4-16
 configuring, 4-13
 confirming status, 4-15
 connecting to network, 4-14
 security measures, 4-10
 security mode, 4-18
 security notice, xv
 troubleshooting, T-8
 wireless LAN status, 4-15
Workgroup name, 4-7

